

AP/MALDI PDF Source for the Agilent 1100 Series LC/MSD ion trap

Installation, Operation and Maintenance Manual

June 30, 2004

Warning

Optical parts of the AP/MALDI PDF source should be handled with **extreme** care. Touching them with bare fingers, storing them in or exposing them to dirty or dusty environments can result in permanent damage to some optical components. Be aware that the warranty does not extend to the fiber optical cable, which requires special care during storage, installation, and operation of the AP/MALDI PDF source. Any finger tapping, dirt deposition, or exposing to a dirty environment will result in burning the fiber ends. An optical fiber is shipped with special protective caps on its ends. After removing the fiber optic protective caps, please keep them in clean conditions and put the protective caps back on the fiber ends immediately after the cable is detached from a connector or the cable is not used. If cleaning of the fiber end is required please refer to the Maintenance/Troubleshooting section (Section 8) of this manual for a cleaning procedure. It is a good idea to proceed with fiber end cleaning every time an exposure to dirt or a contamination of a fiber end surface is suspected. In normal operation with proper care an optical fiber will have a long lifetime. We've included a spare optical fiber cable in case your first optical fiber cable is accidentally damaged. Additional fiber cables **MUST** be ordered from the AP/MALDI PDF source manufacturer, MassTech, or your sales agent. **ONLY** replace the fiber with an exact replacement from the manufacturer, MassTech (Replacement Part number 6140004)

For maintenance or repair please contact your sales agent or the manufacturer directly:

MASSTECH, INC

6992 Columbia Gateway Dr
Columbia MD 21046
USA
Phone: (443) 539 1758
Fax: (443) 539 1757

Table of Contents

PREFACE	II
1 INTRODUCTION: AP/MALDI PDF – A NEW SOURCE OF ATMOSPHERIC PRESSURE IONS	1
1.1 QUICKSTART OPERATION	3
2 AP/MALDI BASIC PRINCIPLES	5
3 PDF PRINCIPLE OF OPERATION	7
4 SAFETY PROCEDURES WHILE USING AP/MALDI PDF	8
4.1 SAFETY PRECAUTIONS	8
4.2 OPERATOR CONTROLS AND INDICATORS	11
5 SOURCE INSTALLATION	12
5.1 CHECKING THAT ALL COMPONENTS HAVE BEEN RECEIVED	12
5.2 INSTALLATION OF THE SOURCE	16
5.3 WIRING OF THE CONTROL UNIT AND THE SOURCE:.....	21
5.4 FINE ADJUSTMENTS TO SOURCE.....	26
5.5 SOURCE REMOVAL AND UNINSTALLATION	28
6 SAMPLE PREPARATION	29
6.1 LOADING/UNLOADING THE TARGET PLATE.....	30
7 AP/MALDI PDF OPERATION	32
7.1 INSTALLING THE TARGET SOFTWARE AND USB DRIVERS	32
7.2 STARTING THE TARGET SOFTWARE	33
7.3 POSITIONING/SIZING OF THE RED (LASER) CROSS-HAIRS	35
7.4 CALIBRATION OF THE VIDEO CAPTURE SAMPLE POSITIONING SYSTEM	36
7.5 RUNNING AP/MALDI ON THE LC/MSD INSTRUMENT	41
7.6 SETTING THE LC/MSD PARAMETERS	44
7.7 PDF OPERATION	47
7.8 MANUAL MODE OF OPERATION	50
7.9 AUTOMATED MODE OF OPERATION	51
8 MAINTENANCE —TROUBLESHOOTING THE SOURCE	55
8.1 PROBLEM: INSUFFICIENT ION PRODUCTION - LACK OF LASER POWER BEING DELIVERED TO THE TARGET SPOT.	55
8.2 PROBLEM: THE LASER BEAM IS NOT WELL-FOCUSED	56
8.3 PROBLEM: THE LASER BEAM FOCAL POINT AT THE TARGET PLATE IS NOT ALIGNED WITH THE CAPILLARY EXTENSION.	57
8.4 PROBLEM: THE ION TRANSPORT INTO THE LC/MSD INSTRUMENT IS CLOGGED/BLOCKED.	61
8.5 PROBLEM: THE OPTICAL FIBER ENDS NEED TO BE CLEANED.....	62
8.6 PROBLEM: SPECTRAL RESPONSE WITH HIGH BACKGROUND AND MASS-SHIFTED ION PEAKS	63
9 LITERATURE	64
10 WARRANTY INFORMATION – SIX MONTH LIMITED WARRANTY	65
APPENDIX A THERMO LASER SCIENCE OEM 337-SI NITROGEN LASER SPECIFICATIONS ...	66
APPENDIX B ILLUSTRATION OF THE LASER ENERGY ATTENUATION CURVE	67
APPENDIX C WARNING AND IDENTIFICATION LABELS	68

PREFACE

The following symbols are used in this manual to indicate material that should especially be noted because it relates to safety issues.



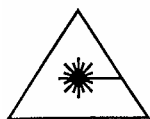

This symbol in the manual margin is used to emphasize the presence of very important operating instructions related to safety especially during installation, uninstallation, maintenance and troubleshooting.



This symbol in the manual margin is used to alert the operator to potential dangerous exposure to hazardous invisible laser radiation.



Operators are strongly encouraged to read this manual before installation, uninstallation, operation, maintenance, or troubleshooting. Operators should pay special attention to paragraphs marked by  and .



DO NOT ATTEMPT services or repairs that are not covered in the Troubleshooting section, Section 8, of this Manual. For services and repairs beyond those specifically provided in the Troubleshooting section, contact the manufacturer, MassTech, Inc. 6992 Columbia Gateway Dr., Columbia, MD 21046 (443) 539-1758.

1 INTRODUCTION: AP/MALDI PDF – A NEW SOURCE OF ATMOSPHERIC PRESSURE IONS

Atmospheric Pressure Matrix-assisted Laser Desorption/Ionization – AP/MALDI:

The AP/MALDI source is designed to produce molecular ions of analytes under normal atmospheric pressure conditions from a mixture of matrix/analyte microcrystals by irradiating these crystals with nitrogen laser pulses. These ions are analyzed by Agilent's LC/MSD trap instrument by recording corresponding mass spectra. The mechanism of **AP/MALDI** ion production is similar to that of **conventional MALDI**. The main difference is that AP/MALDI produces ions under atmospheric pressure conditions **outside** of the instrument vacuum housing. The main consequences are:

- The AP/MALDI source is an external ionization source. It is designed to be easily interchangeable with other sources of Agilent Mass spectrometry instruments like ESI, APCI, nanospray, etc.
- Because the AP/MALDI source operates under atmospheric pressure, the replacement of target (sample) plates is a simple and quick process.
- The AP/MALDI source is designed as an additional external source for Agilent's LC/MSD trap instrument. There are other versions of AP/MALDI sources adopted for other instruments. The process of mass spectra measurement is completely decoupled with the sample ionization process. Thus AP/MALDI inherits all the power of the LC/MSD ion traps: high sensitivity, the stability of calibration, MSⁿ capability, powerful data processing, and spectra interpretation software. However, it also inherits all the limitations of LC/MSD ion traps: the m/z range of LC/MSD is limited to 2.2 kDa in standard mode or 4 kDa in an Extended Mass mode (not available in the LC/MSD VLmodel trap). The AP/MALDI source, like the conventional MALDI source, produces mostly singly-charged ions. As a result, the present capability of the Agilent ion trap limits the mass range of the AP/MALDI- LC/MSD combination to 4,000 Da.
- AP/MALDI is a softer ionization technique compared with conventional vacuum MALDI. This is an important advantage when unstable molecular mass of analyte in a gas phase is to be measured. A detailed discussion of this phenomenon and some examples may be found in publications [1,2].

The AP/MALDI source operates under normal ambient pressure conditions similar to ESI sources. AP/MALDI and ESI sources are interchangeable and typically provide complimentary analytical information. Appropriate use of

both ESI and AP/MALDI sources provides the opportunity to cover the broad range of problems of modern analytical chemistry [1,2,3].

Pulsed Dynamic Focusing Technology – PDF:

AP/MALDI has conventionally used continuous electric fields to extract ions into a mass spectrometer. Pulsed Dynamic Focusing (PDF) Technology applies a new electric field scheme whereby the extraction field is applied for only a brief timed interval after the laser pulse. By removing the electric field while ions are in transit from the target plate surface to the entrance of the mass spectrometer, ions avoid being lost to the entrance tip and walls and are instead entrained by the gas flow into the MS. The technique is termed Pulsed Dynamic Focusing because the electric field (between the target plate and MS inlet) is *pulsed* to zero at an optimal time, so that ions are *dynamically focused* into the MS. PDF Technology significantly improves the signal level and reliability of AP/MALDI [4].

Advantages of PDF are:

- Increased transmission efficiency of ions into MS.
- Higher Ionization Efficiency at greater Voltage setting.
- Greater sample throughput when larger laser spot size is applied.
- Insensitivity to laser misalignments.

PDF is integrated directly into the AP/MALDI PDF ion source and is controlled via the Target Control software.

1.1 QUICKSTART OPERATION

This section covers basic operation of the AP/MALDI PDF source after the AP/MALDI PDF source, Target software, and the LC/MSD mass spectrometer have been properly installed and set-up.

Once the Ion source and control unit are installed and connected to each other and the mass spectrometer according to Section 5 of this manual, the operation steps are as follows. NOTE: All installation and uninstallation procedures must be done with the Power TURNED OFF. Before proceeding you are strongly urged to read the Safety procedures in Section 4 of this manual.



1. Close the Ion source, turn on the Control unit, and run the Target software on the PC connected to the Mass Spectrometer. Wait until the initialization is completed and “Ready” is displayed in the status field of the Target software.
2. Since the LC/MSD software is normally optimized for the Electrospray source, you must adjust the LC/MSD software’s parameters so it is optimized for AP/MALDI:

Set the LC/MSD software for “nanospray” with these changes:
Capillary voltage: 3-3.5kV; Accu Time=100 to 500ms,
PDF Pulse Delay Time 20 μ s.

3. Prepare a MALDI Sample according to Section 6 of this manual. (a typical sample preparation procedure is the same as is done for conventional vacuum MALDI).
4. Load the Target plate containing the samples into the Ion source target plate holder according to Section 6.1 of this manual. Ensure that you close and “click” in the Source securely.
5. Use the Target software to fire the laser and test your samples. To operate in Manual mode (spot by spot spectra measurement), make sure that the AutoSequence toolbar icon is unchecked, and choose a desirable spot using the Target software. Adjust the position of the laser using the target image on the Computer screen, if necessary. Start the Laser firing and (optionally) spiral/raster motion (in the Target program). After satisfactory data collection, switch to LC/MSD data acquisition. Now you can repeat the procedure for other spots. (a detailed explanation of automatic operation is included as Section 7.5 of this manual).

6. When you finish the data acquisition, stop LC/MSD data acquisition (by using the LC/MSD software), and stop laser firing and target motion (by using the Target software). Open the source and remove the used target plate.
7. Replace the target plate, close the Ion source, and repeat step 5 to get spectra from a new target plate.

2 AP/MALDI BASIC PRINCIPLES

Understanding the basic principles of the AP/MALDI PDF source is not strictly necessary for successful practical use of the source. However, a brief summary of the apparatus and operating mechanisms are provided here for completeness. The description of the AP/MALDI PDF source is better understood by explaining the AP/MALDI operation separately from the PDF technology. Thus this section will first focus on the description of the AP/MALDI process, while Section 3 will describe the PDF operating principles.

Ion Source:

A simplified scheme of the AP/MALDI PDF source is presented in Fig. 2-1 below.

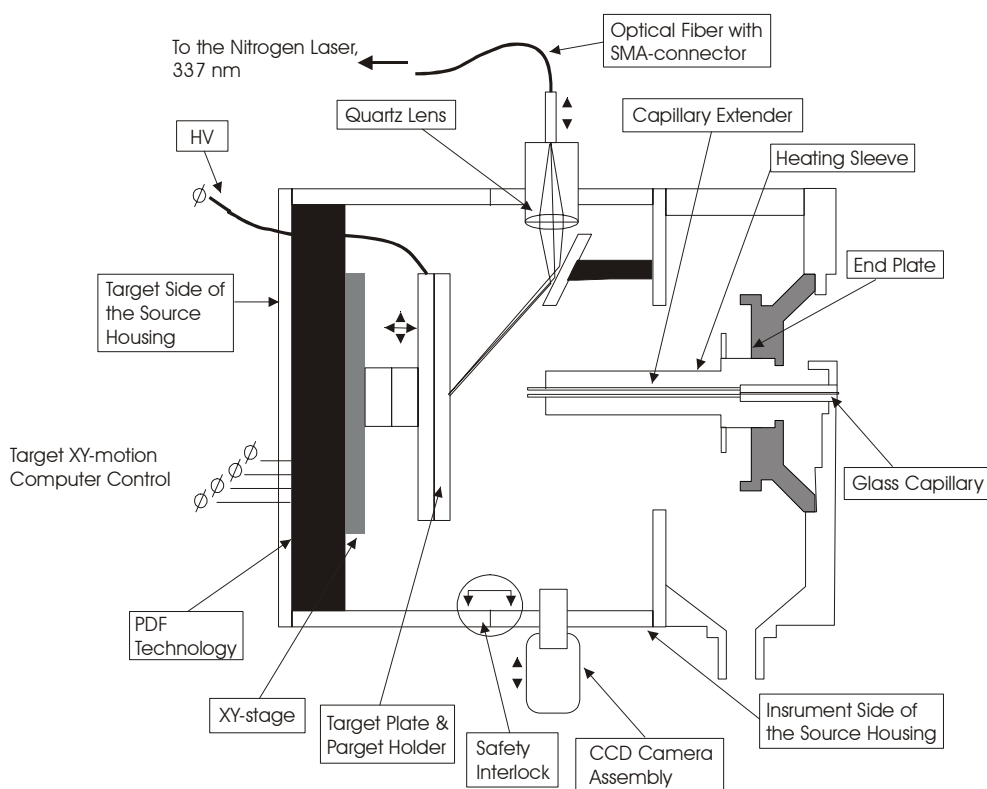

Fig. 2-1. Simplified schematic diagram of the AP/MALDI PDF source installed on Agilent's LC/MSD trap instrument.

The following explanation of AP/MALDI basics will become clearer as you set up your unit. The AP/MALDI PDF ion source is mounted inside a Housing. The source **Housing** is attached to the **LC/MSD Inlet Flange**. Ions produced inside the source **Housing** travel toward the inlet orifice of the **LC/MSD** with a stream of gas. The source Housing consists of two connected halves, the **Target Side of the Source Housing** and the **Instrument Side of the Source Housing**. MALDI samples are deposited onto the surface of a replaceable **Target Plate** that is slipped into a **Target Plate Holder**. Up to 96 sample spots can be deposited on the surface of each **Target Plate**. High Voltage (typically, 3 kV) is applied to a **Capillary Extension** to assist the transportation of produced ions toward the inlet orifice. Sample material deposited on the surface of a **Target Plate** is irradiated with UV laser light pulses. A Nitrogen Laser (wavelength 337nm) is mounted inside a Control Unit (not shown in Fig. 2-1) and is connected to the AP/MALDI PDF source by **Optical Fiber**. UV laser light pulses transmitted through the **Optical Fiber** are focused by a **Quartz Lens** and directed onto the target surface with a **Mirror**. A **CCD Camera** and imaging optics enable the user to monitor the target plate motion and the sample evaporation processes from a COMPUTER's video capture screen (not shown in Fig. 2-1). Inside the source Housing there is also a source of visible light (not shown in Fig. 2-1) to illuminate the target plate surface. The AP/MALDI PDF source can be easily opened to replace **Target Plates**. A **Safety Interlock** prevents the laser from being switched **ON** or **HV** to be applied to a **Capillary Extension** if the source is **OPENED**.

Control Unit:

The second important part of the AP/MALDI PDF unit is a **Control Unit** (not shown in the figure). UV laser and XY-stage controllers are mounted inside it. The Control Unit is connected to the source by an Optical Fiber and electrical cable. One more cable connects the Control Unit with a PC computer's serial (COM) port that controls the target plate motion and laser firing. Either a separate (PC) computer or an LC/MSD control computer can be used to operate the AP/MALDI PDF source. Both USB and RS232 Serial connections are available to communicate between the Control Unit and a computer. Inside the Control Unit is a nitrogen laser made by Thermo Laser Science. (Appendix A is a list of specifications for this OEM laser).

3 PDF PRINCIPLE OF OPERATION

Pulsed Dynamic Focusing (PDF) is an added feature to AP/MALDI which changes the electric field scheme in the ion source so that ions are focused into the MS inlet. PDF technology allows more reliable operation of AP/MALDI and improves performance.

The voltage scheme for PDF is described in Figure 3-1. Each laser pulse is used to trigger a high voltage switch, after a user-defined timed interval (pulse delay). The switch immediately removes the electric field between the target plate and capillary for a hold time of >1ms, and then afterwards allows the electric field to return back to its original level. The electric field is removed by pulsing the target plate to the same voltage as the capillary for the set hold time.

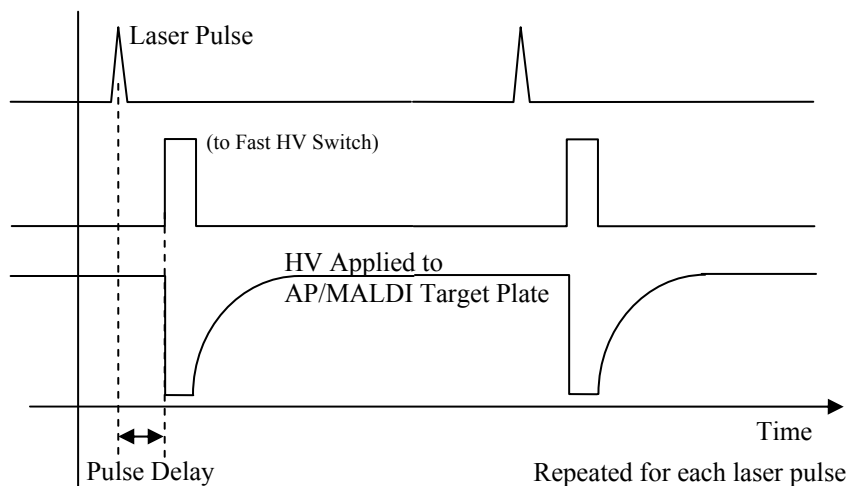

Figure 3-1. Voltage scheme for AP/MALDI PDF

PDF improves S/N ratio at higher voltages. PDF also allows larger laser spot sizes to be effectively utilized. The combination of working at higher voltages and utilizing larger laser spot areas result in a sensitivity improvement in comparison to classical AP/MALDI without PDF. In addition, PDF technology allows misalignments in the laser position, of up to 1.2 mm (radial off-axis from the capillary axis) to not greatly affect sensitivity.

The user controls the “Pulse Delay” time through Target software so that ion signal is optimized. This is described in Section 7.7.

4 SAFETY PROCEDURES WHILE USING AP/MALDI PDF



If operated properly, the AP/MALDI PDF source is safe. No special knowledge of laser safety or electrical safety is necessary to operate the source. There are two potentially hazardous factors connected with AP/MALDI PDF source installation, operation and maintenance/troubleshooting:

1. **Invisible coherent UV irradiation** 337nm, up to 300 μ J per pulse
2. **High Voltage** up to 5kV DC

To provide the necessary safety, the manufacturer of this product has provided careful protection to users by shielding (housing) and reliable interlocking of the source components from UV radiation and High Voltage, provided that the AP/MALDI PDF source Power is TURNED OFF during installation/uninstallation.

4.1 Safety Precautions



This section describes important precautions that must be observed during AP/MALDI PDF source *installation, operation, and maintenance*. Appropriate precautions can be divided into the following stages:



- **Installing/Uninstalling:** Before the source is installed onto the LC/MSD instrument, uninstalled, or replaced, the LC/MSD instrument must be in either “Standby” or “Shutdown” mode. The same rules, described in the LC/MSD operator’s Manual for the replacement of the standard sources (Electrospray/Nanospray/APCI), are applicable for AP/MALDI, too.



Never switch the power ON at the rear panel of the AP/MALDI PDF Control Unit before the source is ***completely installed***, and optical fiber properly connected at **both ends**.

When uninstalling, again: make sure that the LC/MSD is in Standby or Shutdown mode, switch OFF the power at the rear panel of the AP/MALDI PDF Control Unit; then start any disassembling operations or source detachment. The AP/MALDI PDF source safety interlocks safeguard the user from accidental application of High Voltage or Laser Radiation when the source and Control Unit are covered in their housing.

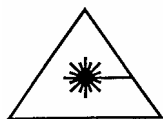

IMPORTANT: Whenever the optical fiber is being detached from or connected to the Control Unit or the Source housing, **MAKE SURE** the power switch on the Control Unit is **OFF**.



- **Target plate loading/unloading:** You need to open the AP/MALDI PDF source to load or unload the target plate. It is recommended that you first switch the LC/MSD instrument to either “Standby” or “Shutdown” mode, stop laser firing (Click on the “Stop “ button in the AP/MALDI PDF source “Target” software) *so that the “Laser ON” indicator on the front panel of Control Unit is OFF*. After that, proceed with loading/unloading of the sample as described in Section 6.1 of this Manual. If by accident you open the source while the LC/MSD instrument is recording the spectrum (HV is ON) and/or the Laser is firing, the AP/MALDI PDF source safety interlocks automatically switch the High Voltage and the Laser OFF.

In addition, depending on the drying gas temperature used in the source, the sample plate may become hot.



Caution: Target plate may be hot!

- **Mass Spectra recording:** Normally, the recording of AP/MALDI PDF spectra is the computer’s job. The source at that time is closed and attached to the LC/MSD instrument, which excludes any possibility of High Voltage shock or laser radiation exposure. Once again, if by accident you open the source while the LC/MSD instrument is recording the spectrum (HV is ON) and/or the Laser is firing, the AP/MALDI PDF source safety interlocks automatically switch the High Voltage and the Laser OFF.
- **Maintenance and troubleshooting:** The AP/MALDI PDF source does not require any maintenance, except cleaning of the optical fiber ends. It is strongly recommended that you follow the maintenance and troubleshooting procedures that are described in the “Troubleshooting” section (Section 8) of the present manual.



DO NOT ATTEMPT services or repairs that are not covered in the Troubleshooting section, Section 8 of this Manual. For services and repairs beyond those specifically provided in Section 8, contact the manufacturer, MassTech, Inc. 6992 Columbia Gateway Dr, Columbia, MD 21046 (443) 539 1758

Remember: Only personnel specifically qualified for laser/high voltage jobs can ignore the following safety rules:

- **Never defeat or bypass interlocks**
- **Never open the cover of the Control Unit**
- **During the Optical Fiber replacement or removal, the Power at the Control Unit must be OFF**
- **Never switch the Power ON at the Control Unit if the AP/MALDI PDF source is not properly attached to the LC/MSD instrument or the optical fiber is not properly installed.**

4.2 Operator Controls and Indicators

The two figures below illustrate the front and back plate of the AP/MALDI PDF Control Unit.

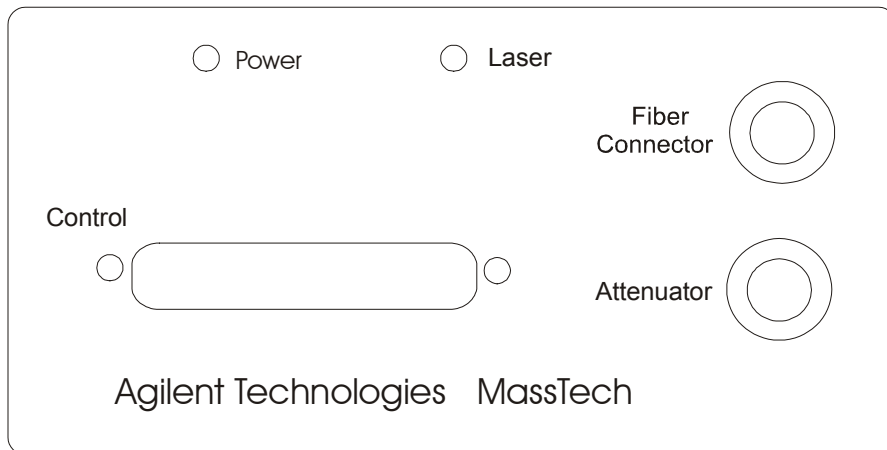

Fig. 4-1 The Control Unit Front Plate

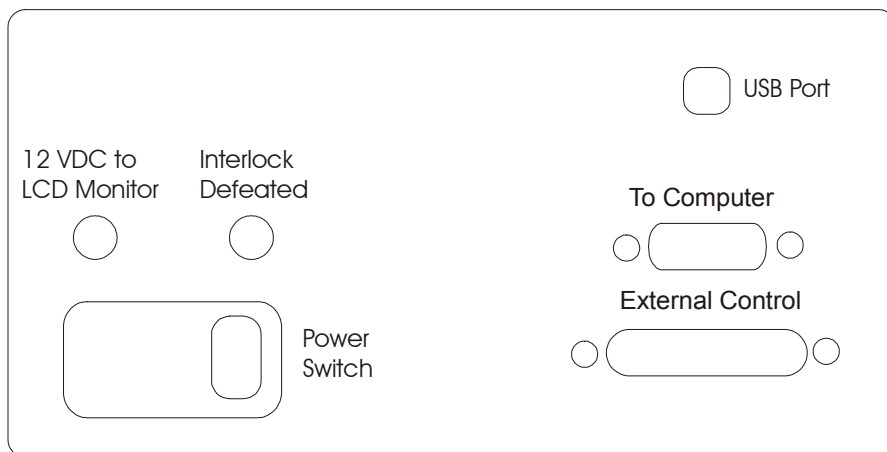

Fig. 4-2 The Control Unit Back Plate

5 SOURCE INSTALLATION

5.1 Checking that all components have been received.

Before you start installing your source, ensure that all necessary Parts and Accessories have been delivered. Figures 5-1 through 5-7 below show these components and introduce some definitions and part names used in the installation explanations.

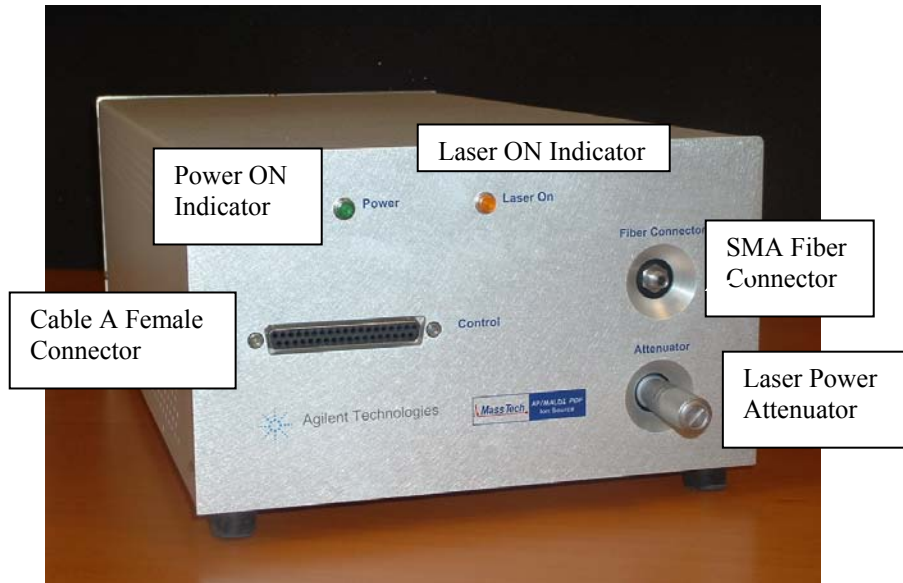

Fig. 5-1 Control Unit Front View

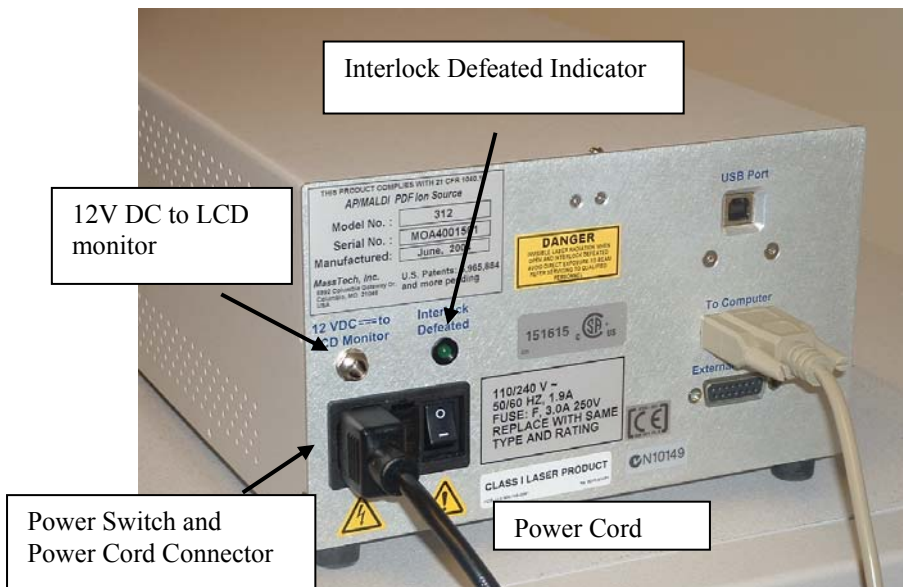

Fig. 5-2 Control Unit Rear View

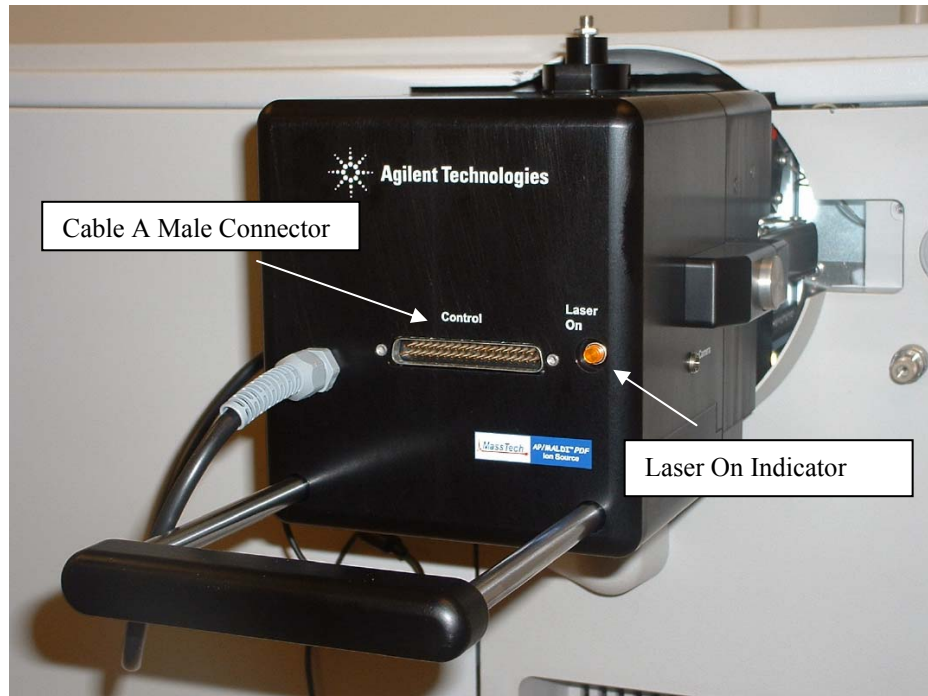

Fig. 5-3 Ion Source for Agilent's LC/MSD trap

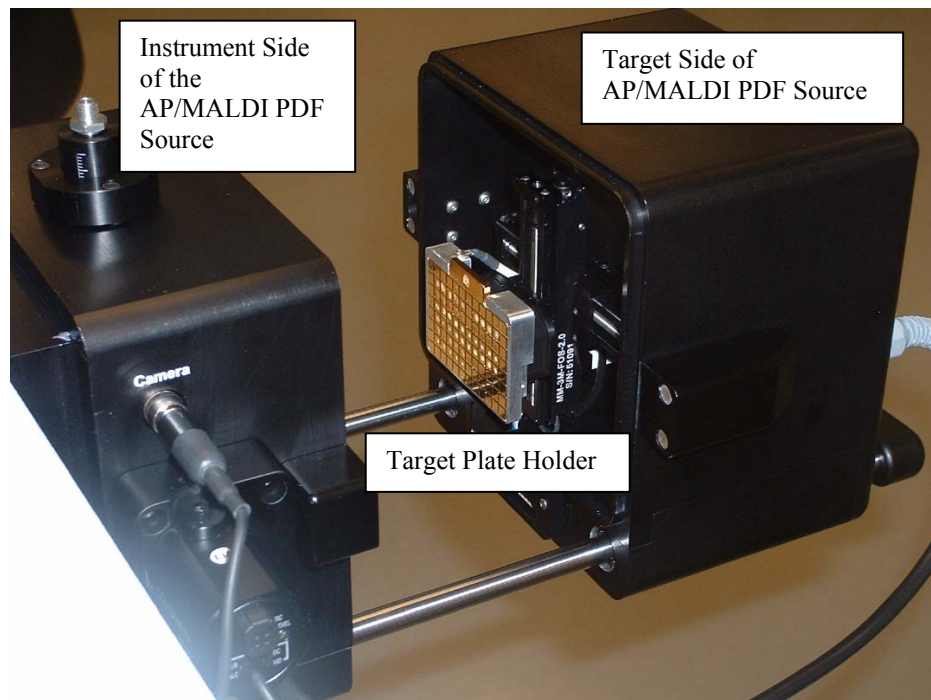

Fig. 5-4 The AP/MALDI ion source opened illustrating the 96-spot target plate holder.

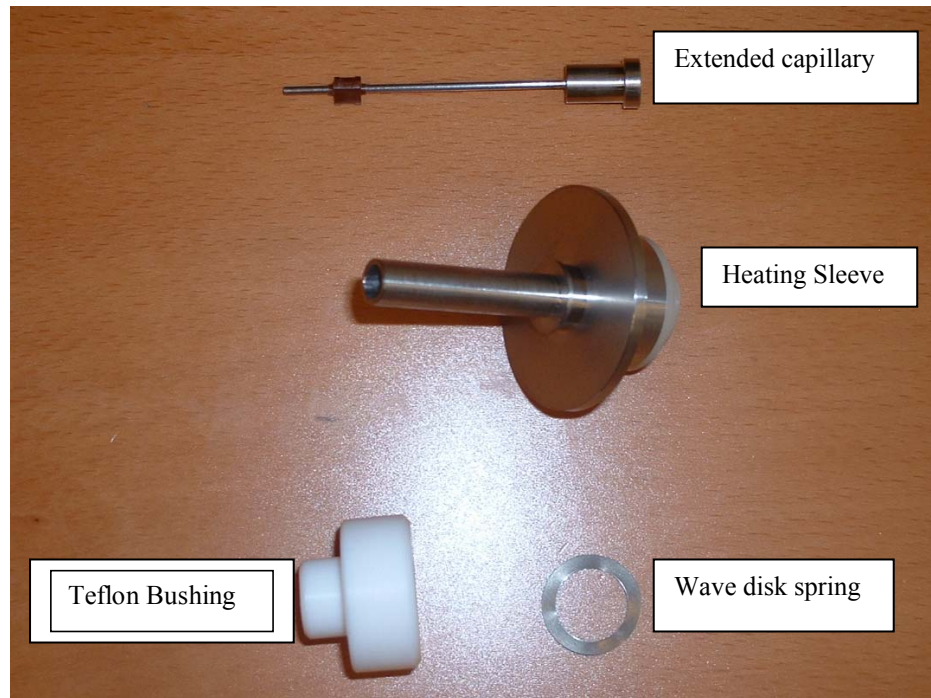

Fig. 5-5 Necessary Components for assembling the Capillary Extension (included in the shipment).

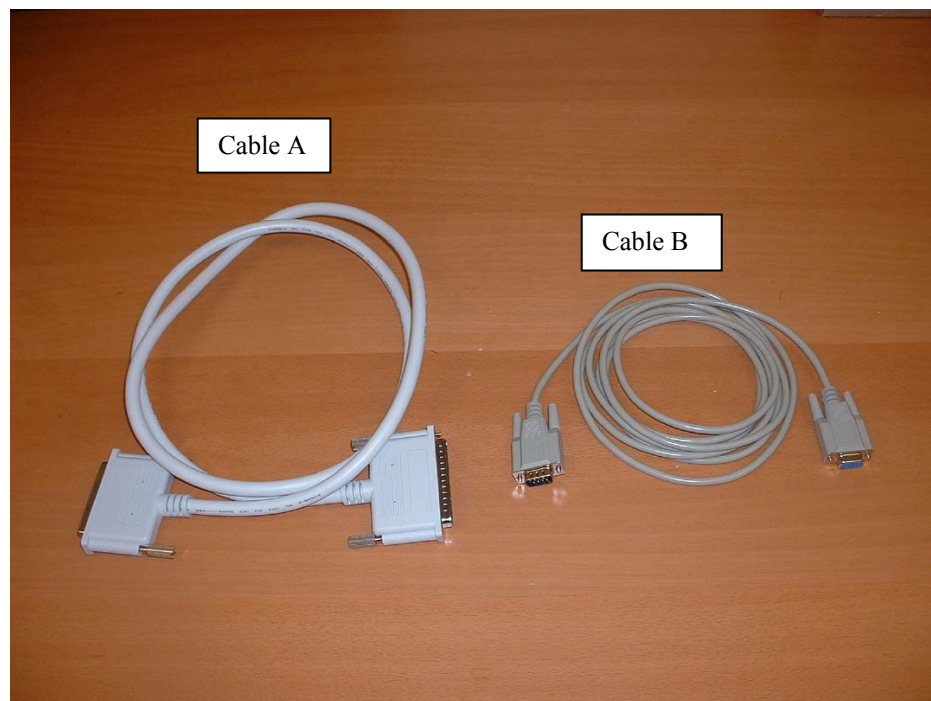

Fig. 5-6 Cable A (Control Unit – to - Source Cable) and Cable B (Control Unit – to - Serial Port of PC computer Cable).

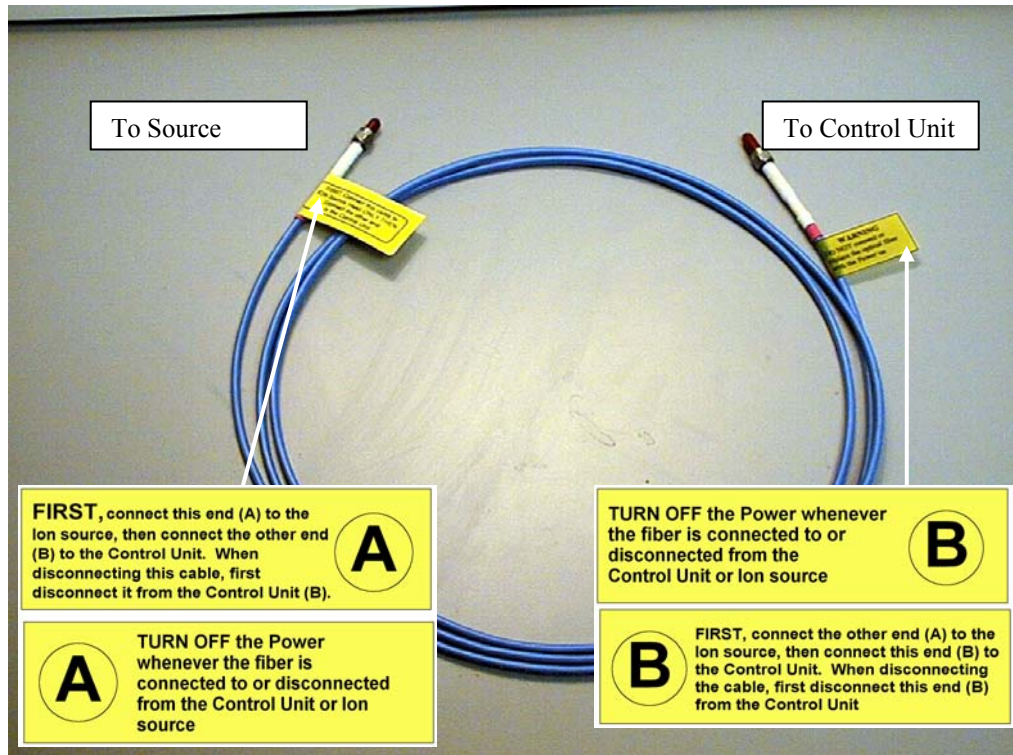
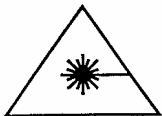

Fig. 5-7 Optical UV-grade Fiber with SMA-connectors labeled on both sides. SMA-connectors on both sides are covered with protective plastic caps. (The shipment includes one spare Optical cable, not shown in the figure).



You must turn OFF the Control Unit (so the laser cannot be accidentally fired) whenever you have the optical fiber disconnected from either end or plan to disconnect or connect it.

In the event that you need to purchase another optical fiber cable, ONLY replace the fiber with an exact replacement from the manufacturer, MassTech (Replacement Part number 6140004).

5.2 Installation of the Source



Installing/Uninstalling: Before the source is installed onto the LC/MSD instrument, uninstalled, or replaced, the LC/MSD instrument must be in either “Standby” or “Shutdown” mode. The same rules, described in the LC/MSD operator’s Manual for the replacement of the standard sources (Electrospray/Nanospray/APCI), are applicable for AP/MALDI, too.



Never switch the power ON at the rear panel of the AP/MALDI PDF Control Unit before the source is **completely installed**, and optical fiber properly connected at **both ends**, to the AP/MALDI PDF source.

When uninstalling, again, make sure that LC/MSD is in Standby or Shutdown mode; switch OFF the power at the rear panel of the AP/MALDI PDF Control Unit; then start any disassembly operations or source detachment. The AP/MALDI PDF source safety interlocks safeguard the user from accidental application of High Voltage or Laser Radiation when the source and Control Unit are covered in their housing.



IMPORTANT: Whenever the optical fiber is being detached from or connected to the Control Unit or the Source housing, **MAKE SURE** the power switch on the Control Unit is **OFF**.

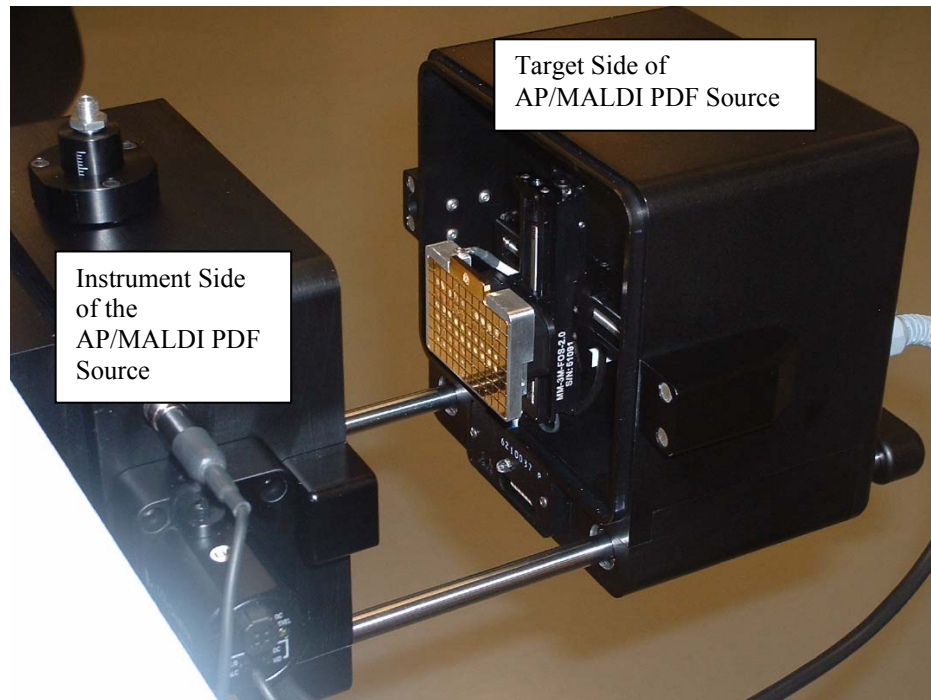

Fig 5-8 The two sides of the AP/MALDI PDF Ion Source

Components of the capillary extension assembly are illustrated below.

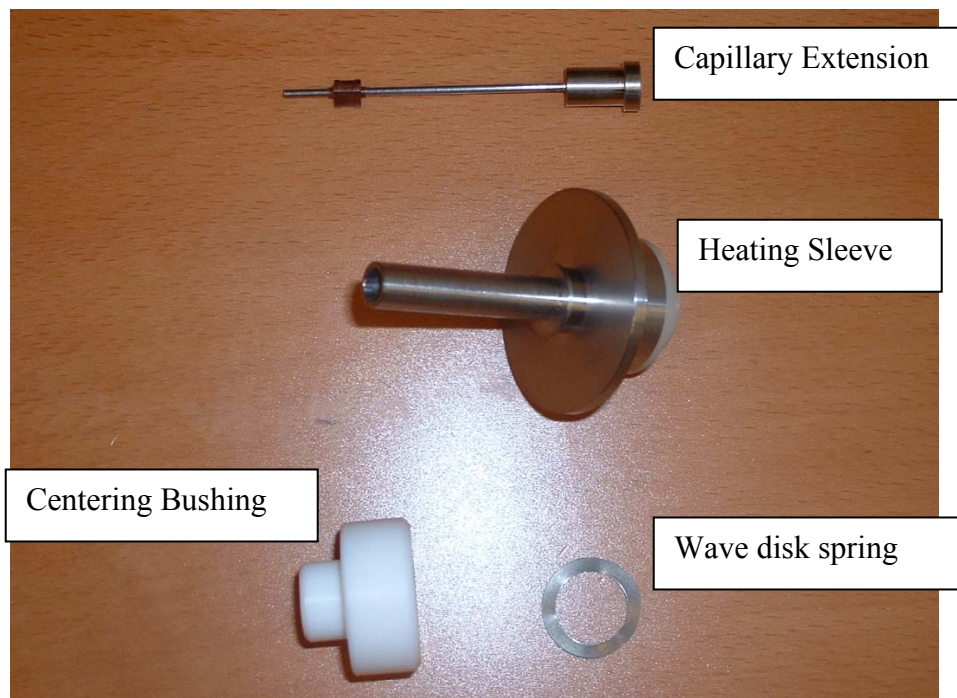

Fig 5-9 The components of the capillary extender



Remove your current source from the LC/MSD leaving an empty inlet flange. First insert the capillary extension by turning in as shown below (Fig. 5-10). GENTLY install the capillary extension on top of the LC/MSD glass capillary. You will feel resistance at first due to the squeezing of the gold-plated spring inside of the capillary extension. DON'T APPLY TOO MUCH FORCE!



Fig 5-10 Installing the Capillary extension to the LC/MSD.

Next, cover the capillary extension with the Heating Sleeve. Screw the Heating Sleeve into the end plate (finger tight).



Fig 5-11 Installing the Heating Sleeve over the Capillary extension

Next, place the Wave disk spring over the Heating Sleeve.



Fig 5-12 Placing the Wave disk spring over the Heating Sleeve

Next, attach the white teflon Centering bushing over the Wave disk spring.

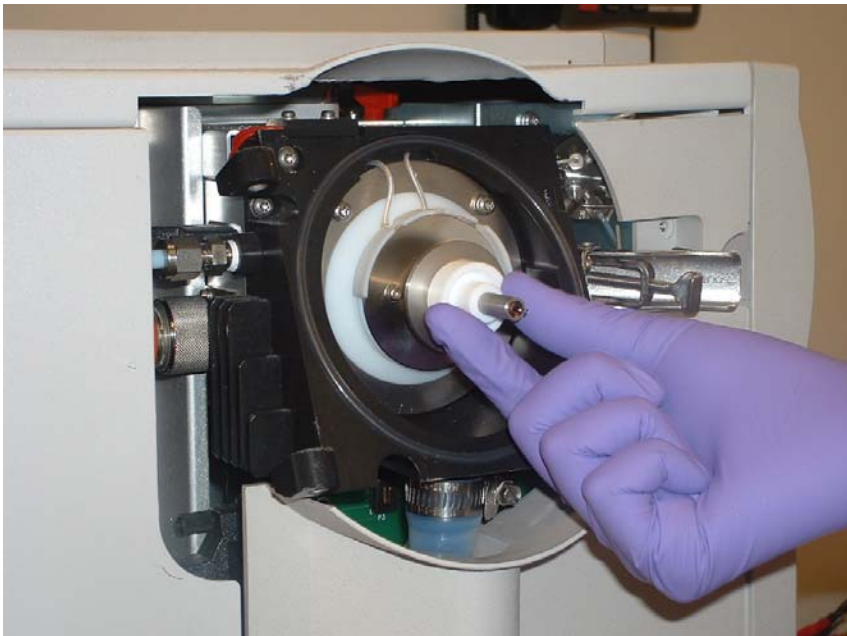

Fig 5-13 Finishing the Capillary Extension Assembly by adding the Teflon Centering Bushing

Now that the Capillary Extension is assembled, mount the AP/MALDI source shown below onto the LC/MSD instrument. Put the metal spike down into its receptor as shown below.



Fig 5-14 Hinging the source into place on the LC/MSD

Close the source and use the latch shown below to lock in the Source by locking the latch into place.



Fig 5-15 Securing both halves of the source and anchoring with the latch on the LC/MSD.

5.3 Wiring of the Control Unit and the Source:



Ensure that the Power on the Control Unit is OFF until the source is completely wired to it.

Connect the black power cord and Cable B to the corresponding connectors at the rear plate of the Control Unit. **No adjustment is necessary for ~110/~127/~220/~240V AC!**



Fig. 5-16 The black power cord and Cable B connected to the back of the Control Unit. **No adjustment is necessary for ~110/~127/~220/~240V AC!**

Connect the other end of Cable B to a free Serial Port on your PC. Either an LC/MSD-instrument computer or a separate PC can be used (Fig. 5-17).

Alternatively, for Windows 2000 operating systems and later, a USB cable can be used to connect the Control Unit to the computer. In this case, connect the USB cable to the back of the control unit, and the other end to a computer's USB port. In this case either the LC/MSD-instrument computer or a separate computer can be used. Only one communication cable needs to be connected between the Control Unit and computer – **DO NOT** connect two serial cables.

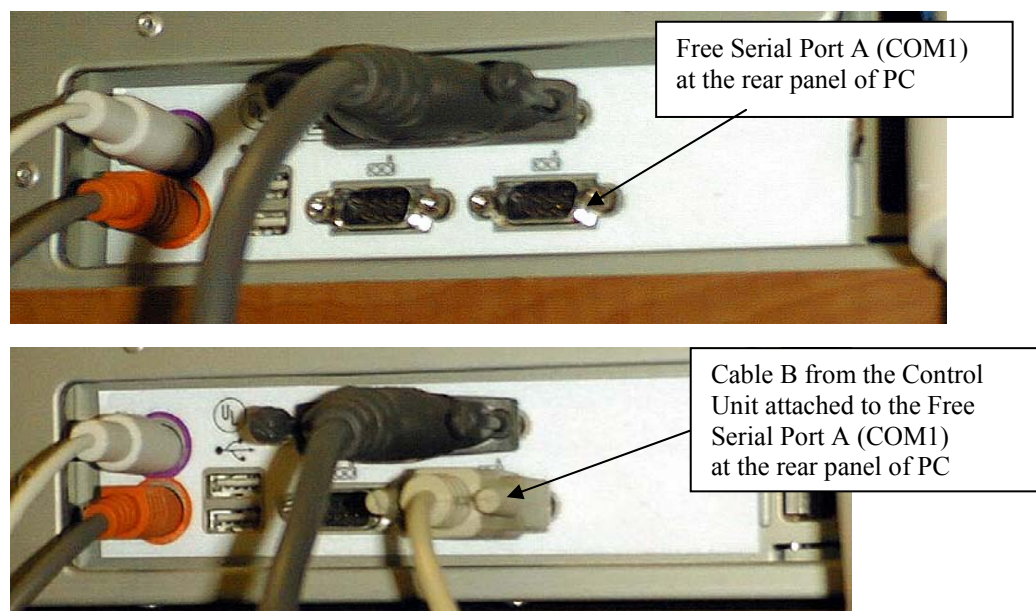

Fig. 5-17 The other end of Cable B connected to a free Serial Port on a PC. Either the LC/MSD-instrument computer or a separate PC can be used.

The video out cable (Fig. 5-18) should be attached to either a video card on your computer or via a USB video adapter cable to your computer. The camera power cable (Fig. 5-18) should be connected to its receptacle above the CCD camera as shown in Fig. 5-19.

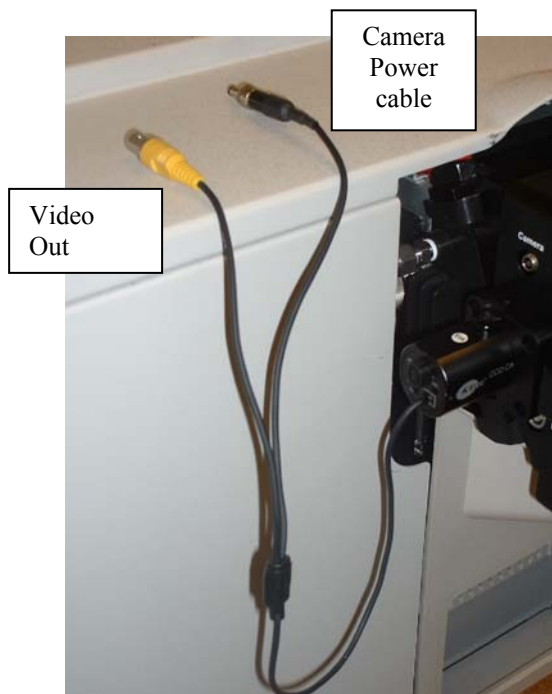

Fig. 5-18 CCD camera cables.

Now, attach the other wires and cables to the source according to Figure 5-19 below. Refer to Fig. 5-20, 5-21 to help with the optical Fiber connections. Refer to Fig. 5-22 to help with the HV connection.

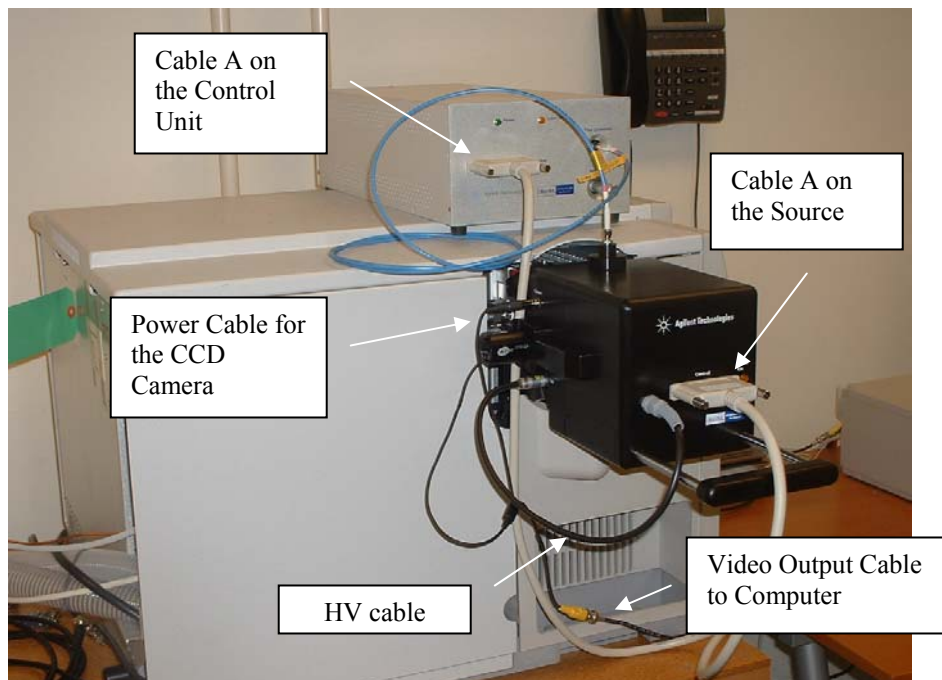

Fig 5-19 The Source with wiring connections completed.



When you install and uninstall the source on the LC/MSD, you must connect or disconnect the optical cable from both the Source and the Control Unit as shown in the figures below.



Fig. 5-20 Connecting fiber to Source (A to A)



Fig. 5-21 Connecting the fiber to the Control Unit (B to B)

Connecting the Optical Fiber to the SMA-connector at the Source.

- Remove the red plastic protection cap.
- Attach the optical fiber securely to the SMA-connector at the Source by pushing the fiber into the connector, and then tightening the nut tightly according to the picture.

Connect the other end of the Optical Fiber to the Control Unit:

- Carefully remove the plastic protection tip from the SMA connector. **Do not touch the optical surface of the Fiber with your fingers.** If you did by mistake, clean the surface with ethanol or methanol, as described in Section 7 of this manual.
- Insert the fiber, pushing it in, then tighten the nut.



When the optical cable is disconnected, any laser fire can emit invisible laser radiation from the ends of the optical cable. Therefore, throughout this manual we warn you of this danger. However, safety interlocks are present which are designed to turn off the laser when an optical fiber is disconnected.

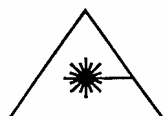

The HV Cable is connected from the Target Side to the Instrument Side of the ion source (Fig. 5-22).



Fig. 5-22. HV Cable Connection.

When complete, your LC/MSD with the AP/MALDI PDF source will look like this:

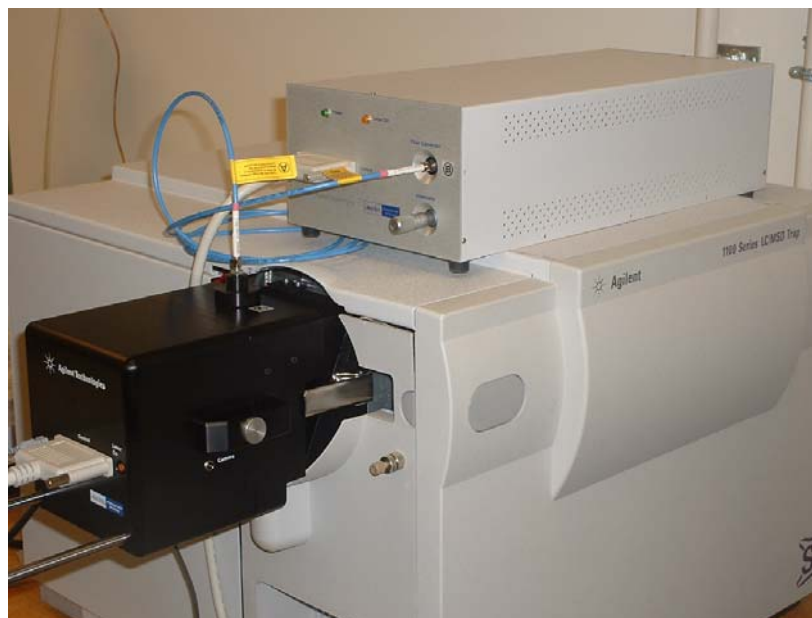

Fig. 5-23 Completed source installation



Before switching on the Power on the Control Unit:

1. Ensure that the HV connector is firmly connected
2. Ensure that both ends of the optical fiber are firmly connected

NOW it is safe to turn on the Control Unit.

5.4 *Fine Adjustments to Source*

If necessary, fine adjustments to the imaging (e.g. Sharpness of focus) can be made as shown in Figs 5-24 and 5-25. But the unit comes pre-tuned.



Fig. 5-24 CCD camera alternative power cable connection for adjustments

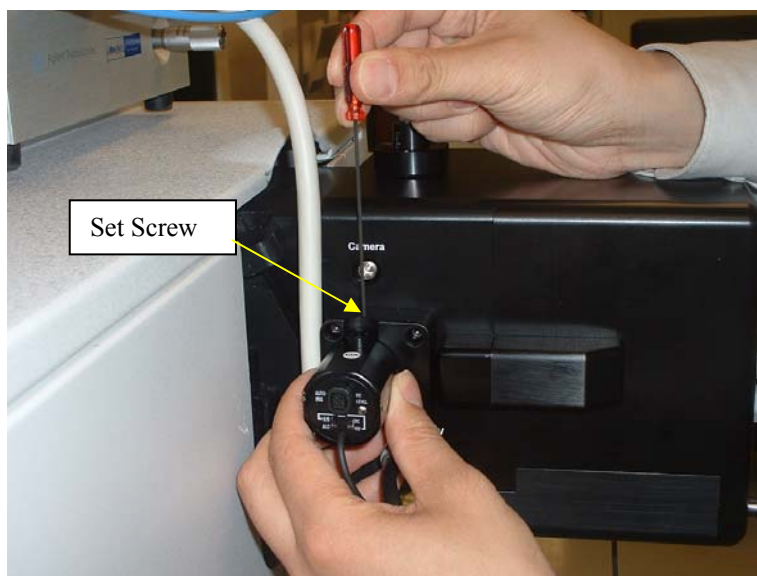

Fig. 5-25 CCD camera focusing.

This procedure can be safely performed even if the source is ON and the laser is firing. Ease the Set Screw, move the camera, then refasten the Set Screw.

NOTE: The Video Capture software also has brightness and contrast controls that can be adjusted to improve image quality. These controls are under the "Video Capture" menu located on the Video Capture box.

If necessary, fine adjustments to the laser positioning and focusing can be made as shown in Fig. 5-26 and Fig. 5-27, respectively but the unit comes pretuned. More details are provided in Sections 8.2 and 8.3.

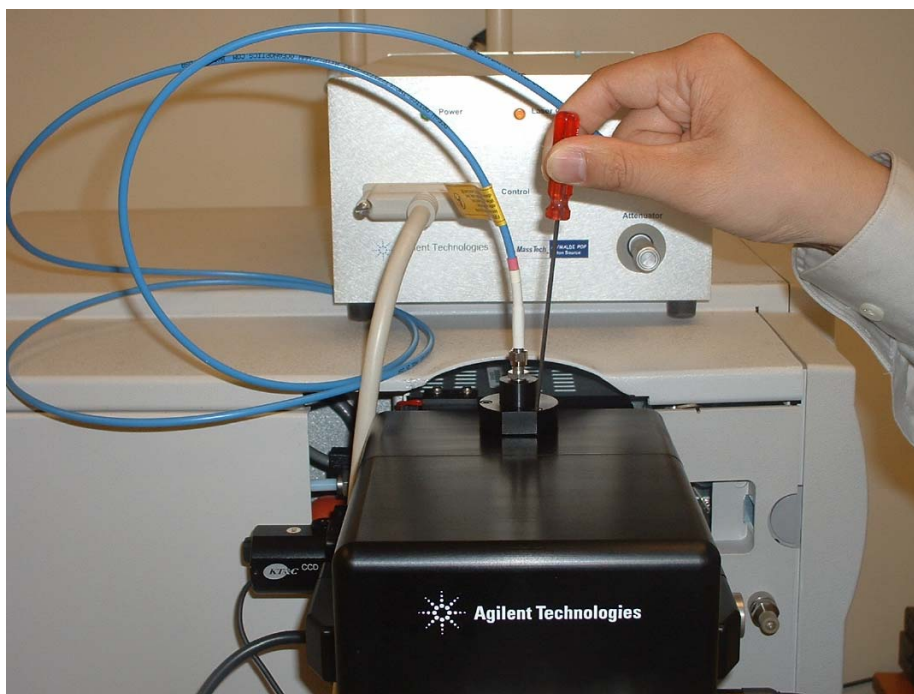

Fig. 5-26. Laser Positioned by adjusting three top screws.

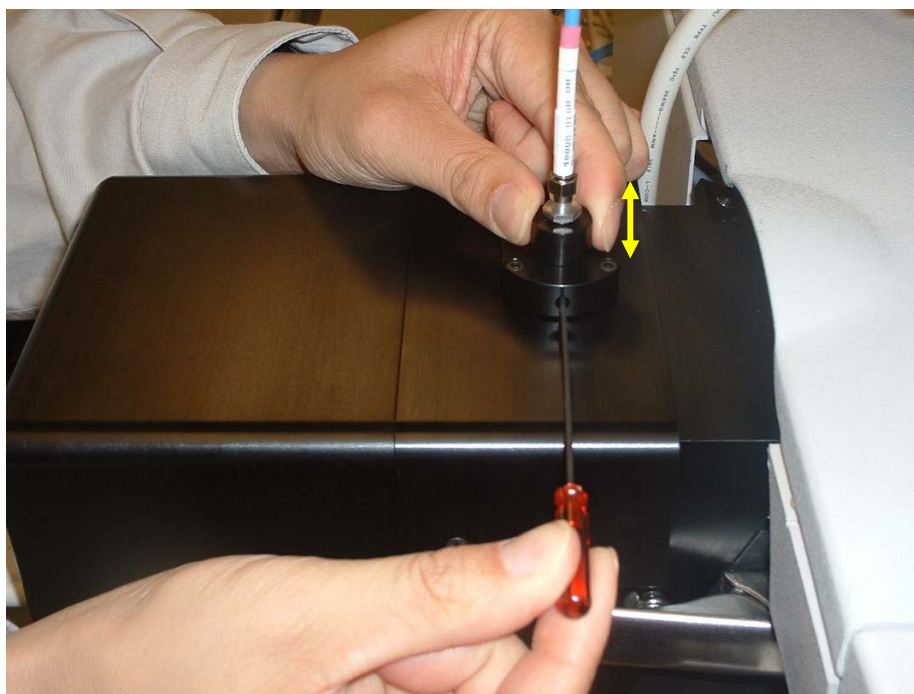

Fig. 5-27. Laser Focused by loosening side set screw, adjusting focusing optic up/down, and then retightening set screw.

5.5 *Source Removal and Uninstallation*

When you need to remove the AP/MALDI ion source in order to put another device on the LC/MSD, **First**,



1. Set the LC/MSD instrument to Standby or OFF mode
2. Turn off the Power on the Control Unit

Then, uninstall the source by reversing the installation procedure just described in Section 5.2.

6 SAMPLE PREPARATION

The same sample preparation techniques and the same matrix used for conventional vacuum MALDI can be used successfully for AP/MALDI sample preparation. The main difference is that the crystal size has no direct influence on the spectrum quality. A typical molar ratio of a sample-to-matrix is between 1:100 and 1:10,000.

Prepare several standard samples for testing the AP/MALDI PDF. The following is a typical sample preparation procedure :

- Carefully clean the Target Plate surface
- For the standards test, α -Cyano-4-hydroxycinnamic acid (α -CHCA) matrix is recommended
- Mix 1:1 matrix solution and analyte solution of some standard peptides (Angiotensin, Bradykinin, Gramicidin S and/or similar) with a concentration of around 500-1000 fmole/ μ L.
- Deposit a droplet of 0.5-2 μ L of the mixture on the target surface and allow it to dry. (Alternatively, matrix and analyte solutions can be deposited on the target separately and then allowed to dry).

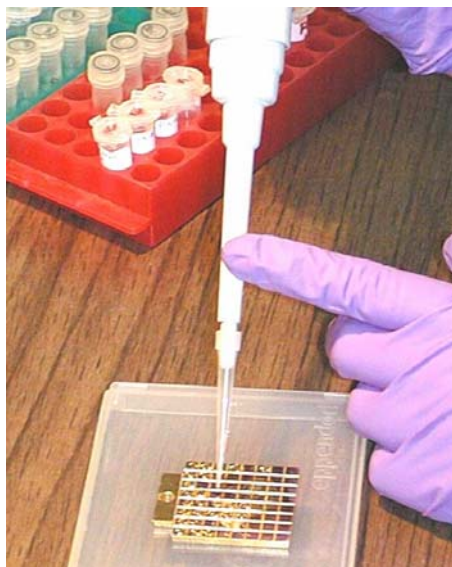

Fig. 6-1 Spotting of several standard samples on a target (sample) plate for testing by AP/MALDI. The sample preparation procedure is basically the same as for original MALDI experiments.

6.1 Loading/Unloading the Target Plate



You need to open the AP/MALDI source to load or unload the target plate. It is recommended that you first switch the LC/MSD instrument to either “Standby” or “Shutdown” mode, stop laser firing (Click on the “Stop “ button in the AP/MALDI source “Target” software) **so that the “Laser ON” indicator on the front panel of Control Unit is OFF**. After that, proceed with loading or unloading of the target plate. If by accident you open the source while the LC/MSD instrument is recording the spectrum (HV is ON) and/or the Laser is firing, the AP/MALDI PDF source safety interlocks automatically switch the High Voltage and the Laser OFF.

To open the source press the round silver button, located on the right hand side of the source, and pull the Target Side of the AP/MALDI PDF source away from the instrument.

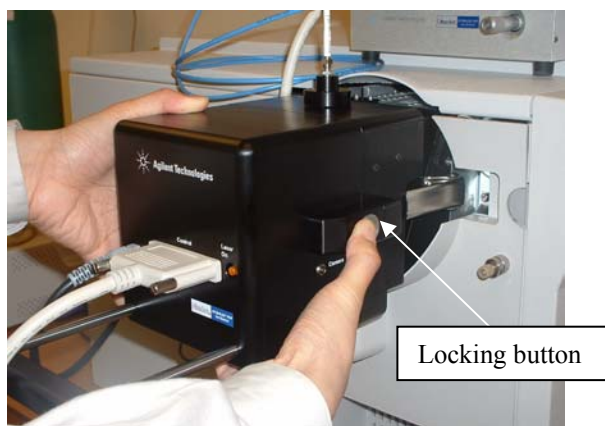

Fig. 6-2 Opening the source by pressing the round silver Locking button and pulling the Target Side of the source away from the instrument.

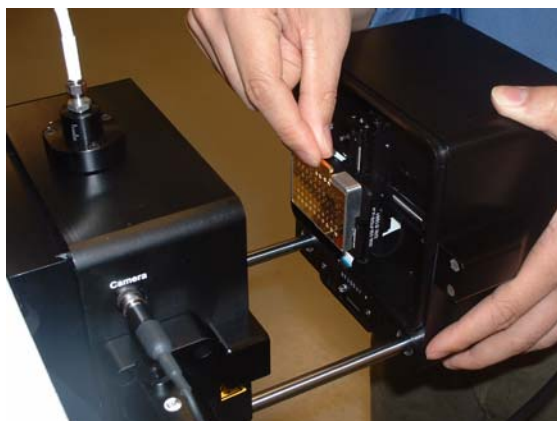

Fig. 6-3 Handling the Target Plate with the prepared sample spots into the Target Plate Holder. The Plate is held in place by a magnet. **Caution – the Target Plate may be hot when unloading.**



When the source is closed, there should be a "click" sound which corresponds to the two halves of the source locking together.



Fig. 6-4 Source "Clicked" into the close position after target (sample) plate is loaded.

If your Target software is already running, you should see the following on the video capture image if the target plate is loaded properly.

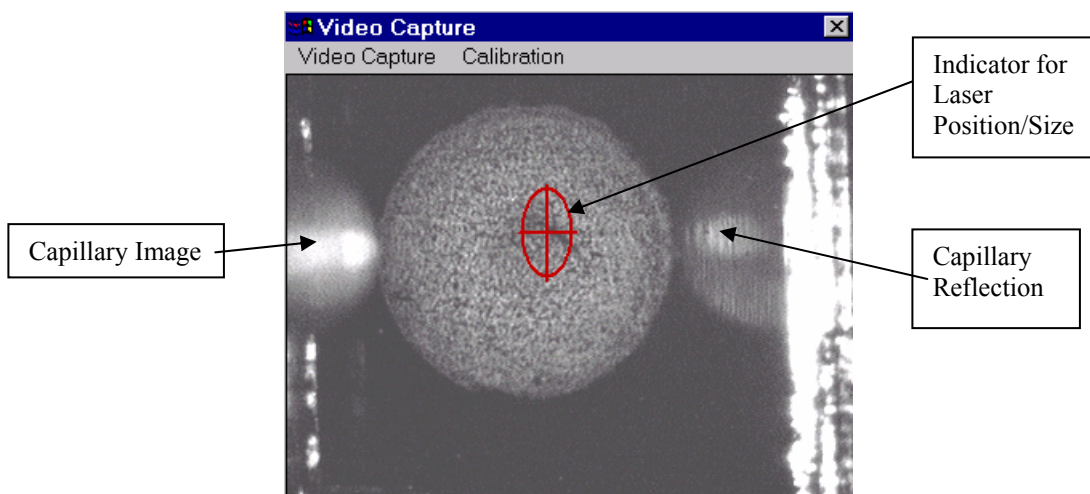

Fig. 6-5 MALDI sample ready for AP/MALDI PDF analysis.

7 AP/MALDI PDF OPERATION

7.1 *Installing the TARGET software and USB Drivers*

Target Version 5.0 software is used to control the AP/MALDI target motion, laser firing and PDF operation.

To install the software for AP/MALDI PDF, follow these steps:
(under Windows NT or 2000 you will need Administrator access)

1. Insert the installation CD and run the Setup.exe program from your CD drive.
2. Chose the desirable location and folder name for the Target software. By default, the folder is: C:\Program Files\MassTech\
3. Follow the next few dialog boxes to completion.

After the Target software installation process is completed, create a shortcut if you wish on your desktop to Target.exe.

If you are using USB to communicate between the Control Unit and computer, you will also need to install the USB Driver for this communication method.

To install the software to enable USB communication on the Control Unit, follow these steps: (under Windows NT or 2000 you will need Administrator access)

1. Ensure that the USB cable is properly connected to the Control Unit and computer.
2. Turn on the power to the Control Unit.
3. The computer should detect “New Hardware Found”
4. When asked for drivers insert the CD, go to the directory ... \drivers to select the driver
5. Follow the next few dialog boxes to completion.

7.2 Starting the TARGET software

Start the Target program by either double-clicking on the desktop shortcut, or the target.exe file. The Target window (Fig. 7-1) appears.

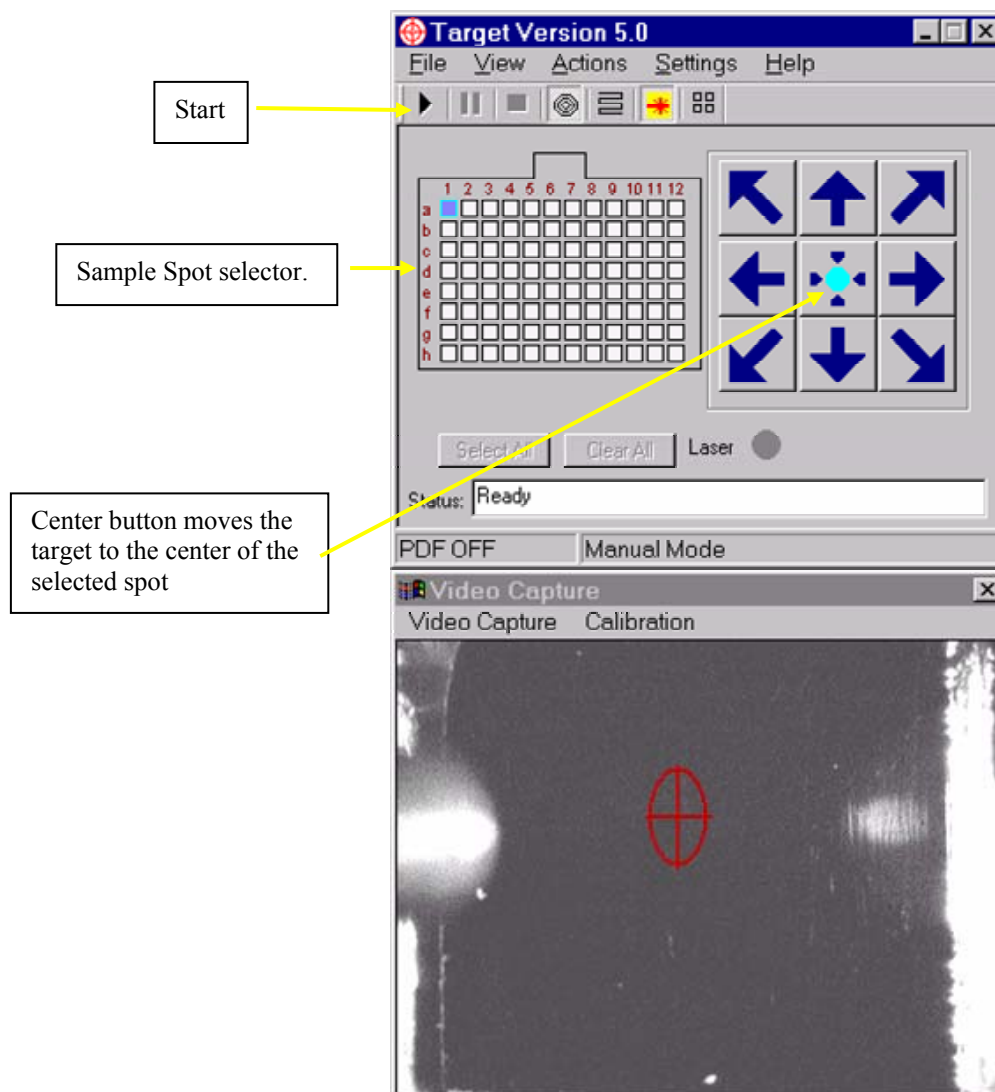

Fig. 7-1. Target software started, properly initialized and ready

At this moment the initialization of the XY stages will start automatically. If everything has been connected properly, you will see target motion on the Video Capture image. During initialization the target moves to its limit positions. After initialization, the target plate's first sample position is A1 (the upper left hand corner of the target (sample) plate).

If the Power On indicator on the Control Unit is OFF, or if the Control Unit is not properly wired to the computer, you will get the message shown in Fig. 7-2. Correct the problem, then reinitialize the software by going to Settings>Set Parameters>General>Init Motors. The Target software can also be reinitialized by exiting and restarting.

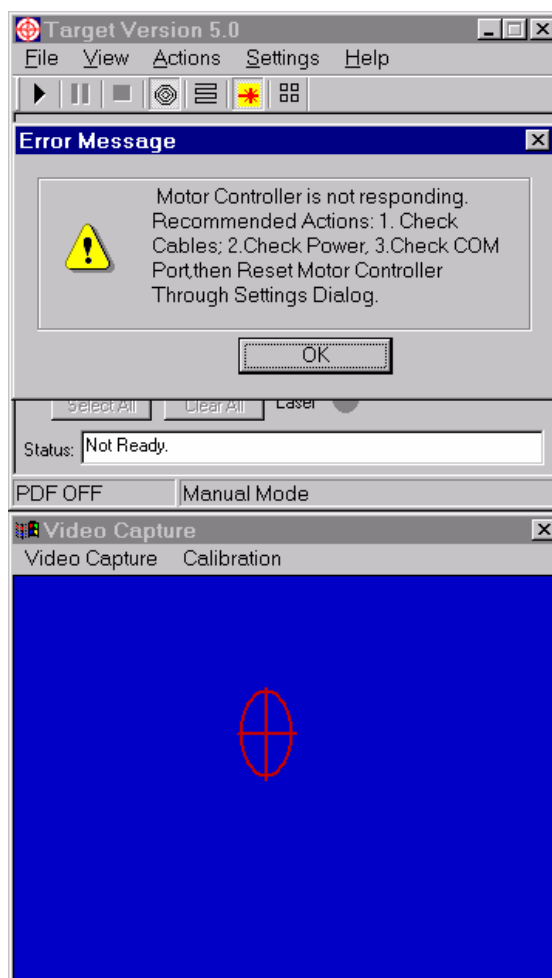

Fig. 7-2 Error Message if control unit is off, connections/communications problem.

After the AP/MALDI PDF source initializes, there can still be instances when the system is in a “Not Ready” state (see Fig. 7-3). The “Not Ready” status can be simply due to the source housing being open – in which case simply close the source for operation. Another possibility for the “Not Ready” status is that an interlock is open. Check to make sure the fiber optic is tightly secured to the connector if this message appears when the source housing is closed.

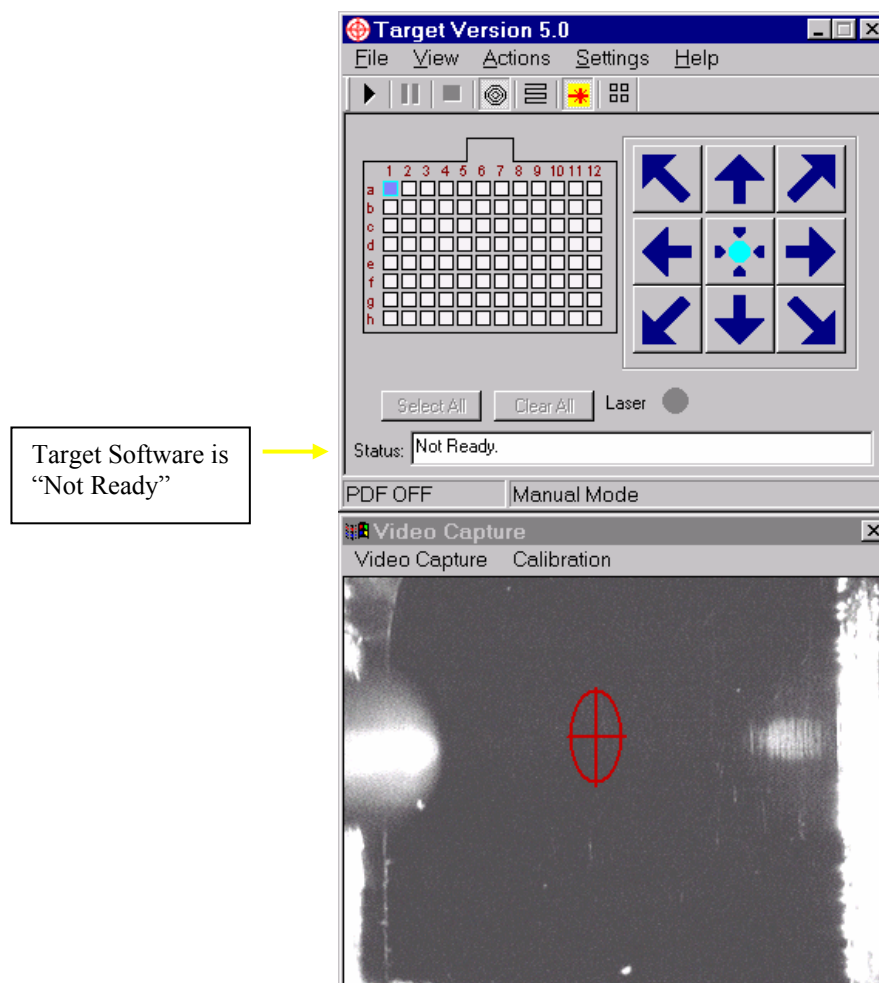

Fig. 7-3 Target software showing "Not Ready" state.

7.3 Positioning/Sizing of the Red (Laser) Cross-Hairs

The Red-Cross Hairs on the Video Capture image are used as an indicator for the laser position and size. The position and size of the Red Cross-Hairs in the Video Capture image should correspond to where the laser is firing and the approximate size of the laser beam area. NOTE: These Red Cross-Hairs are simply an indicator and do not physically adjust the position of the laser.

Adjust the position of the Red Cross-Hairs to coincide with the burn mark of the laser. It is easy to do this with Spiral/Raster Motion deactivated, and using a dense matrix. Hold down the *Ctrl* key and drag and drop the Red Cross-Hairs to the *position* where the laser is firing (Fig. 7-4).

For the size of the Red Target, Hold down the *Shift* key and drag to change the *size* of the laser beam (Fig. 7-5).

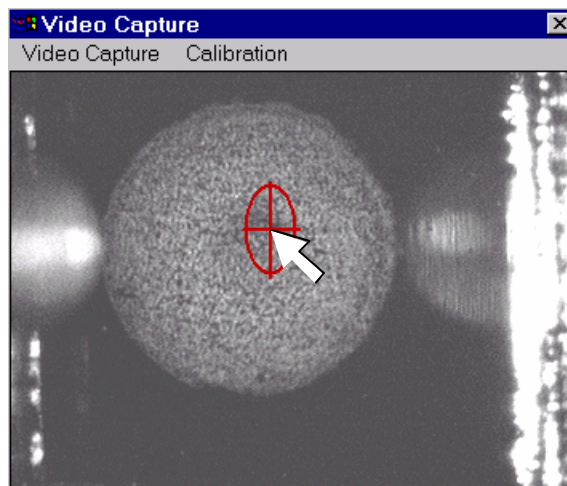

Fig. 7-4 Positioning of the Red (Laser) Cross Hairs by placing the mouse at the center of the Red Cross Hairs, *pressing Ctrl* and dragging the Red Cross Hairs to the position of the laser reflection/ablation.

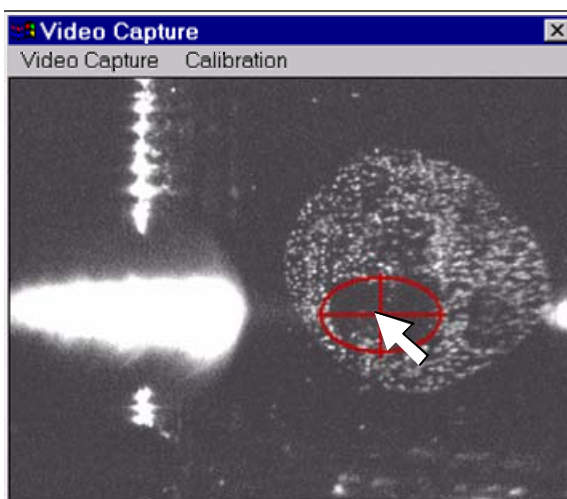

Fig. 7-5 Resizing of the Red (Laser) Target by placing the mouse at the center of the Red Cross Hairs, *pressing Shift* and dragging the mouse to resize the area.

7.4 Calibration of the Video Capture Sample Positioning System

To move the position of the sample that the user desires to be laser irradiated, a “point-and-click” system has been developed through the Video Capture imaging system. This “point-and-click” system uses the **mouse pointer** to **choose** a desired location on the sample image, and **double-clicking the left mouse button** to **move** the sample to the desired location. Before this system can be accurately utilized, it must be calibrated. To calibrate the positioning of the “point-and-click” positioning system, under the Video Capture menu bar item: “Calibration”, choose “Start” (Fig. 7-6).

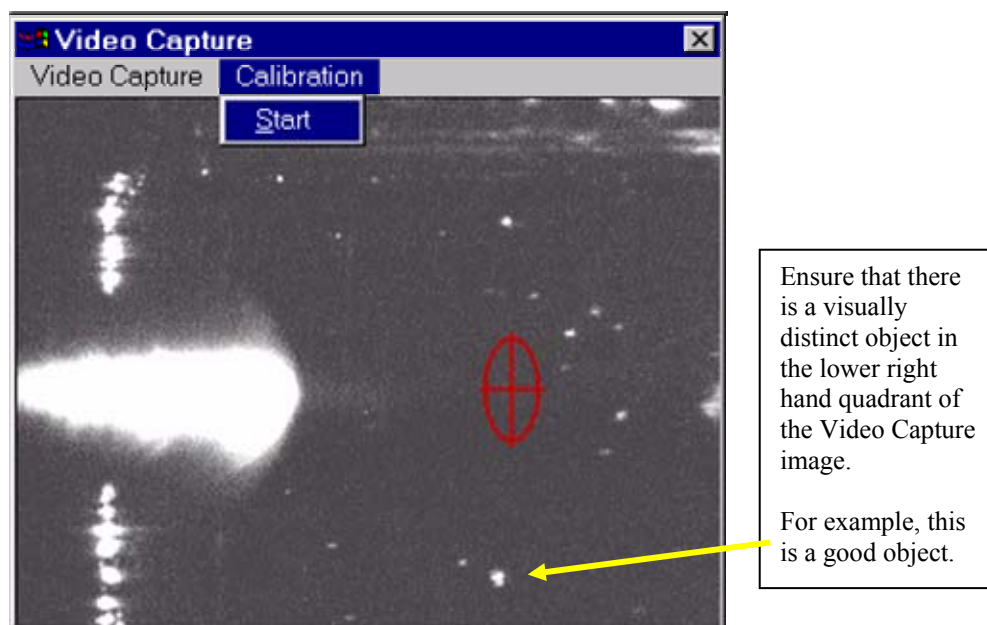

Fig. 7-6 Start of Video Capture sample positioning Calibration Procedure.

After beginning Calibration, a five step procedure will be described in dialog boxes. The first step is to ensure that there is a distinct visual object in the lower right hand quadrant of the screen (see Fig. 7-6). A sample plate with ablated matrix or dilute matrix can be used. If there is no distinct visual object, select another spot, or prepare a new sample (Section 6). Advance through Step 1 by clicking "Next" (Fig. 7-7).

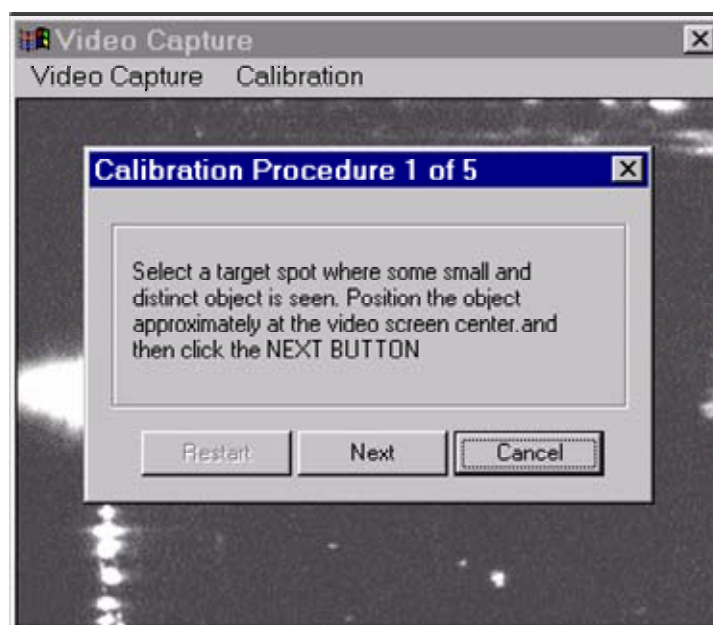

Fig. 7-7 Step 1 of the Video Capture Sample Positioning Calibration

In Step 2 (Fig. 7-8), drag and drop the green target icon to the visually distinct object in the lower right hand quadrant. Then click “Next”.

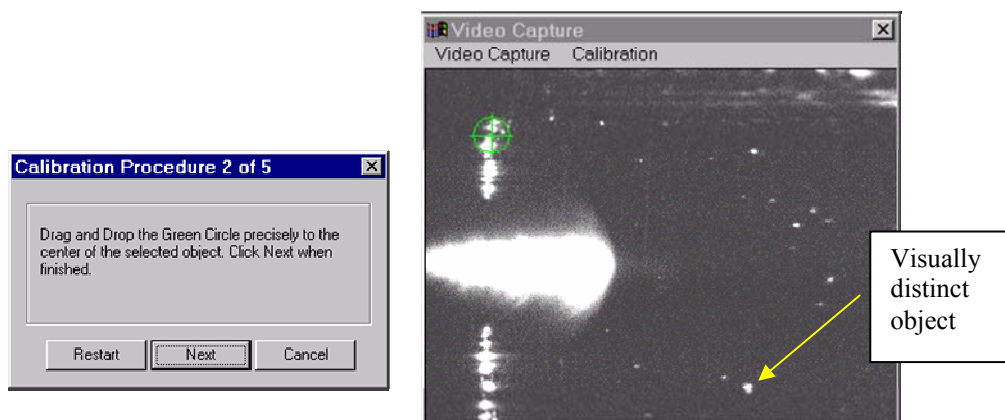

Fig. 7-8a Step 2 of the Video Capture Sample Positioning Calibration showing the position of the original green target.

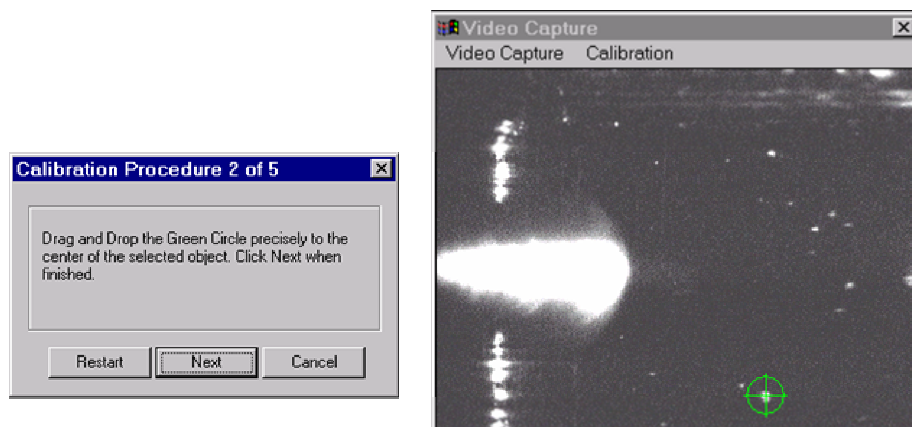

Fig. 7-8b Step 2 of the Video Capture Sample Positioning Calibration showing the green target dragged to a visually distinct object in the lower right hand quadrant.

In Step 3 (Fig. 7-9), the target plate moves horizontally. Watch where the visually distinct object moves to. Drag and drop the green target icon to the same visually distinct object. Then click “Next”.

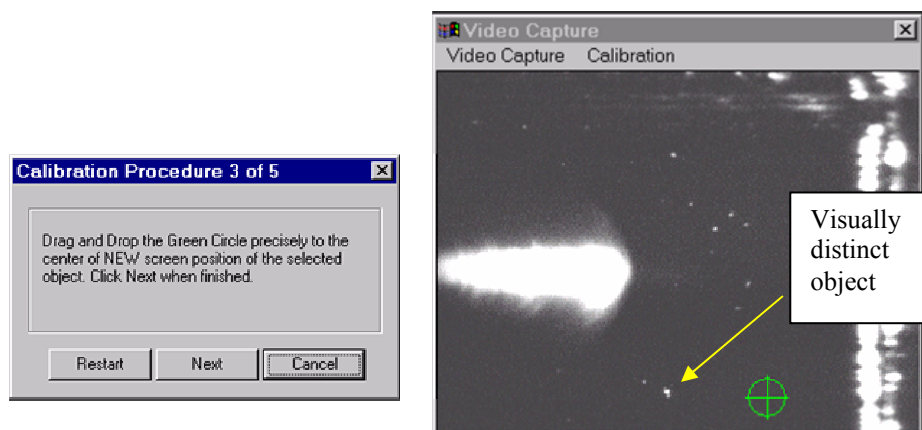

Fig. 7-9a Step 3 of the Video Capture Sample Positioning Calibration showing the visually distinct object moved *horizontally* away from the green target.

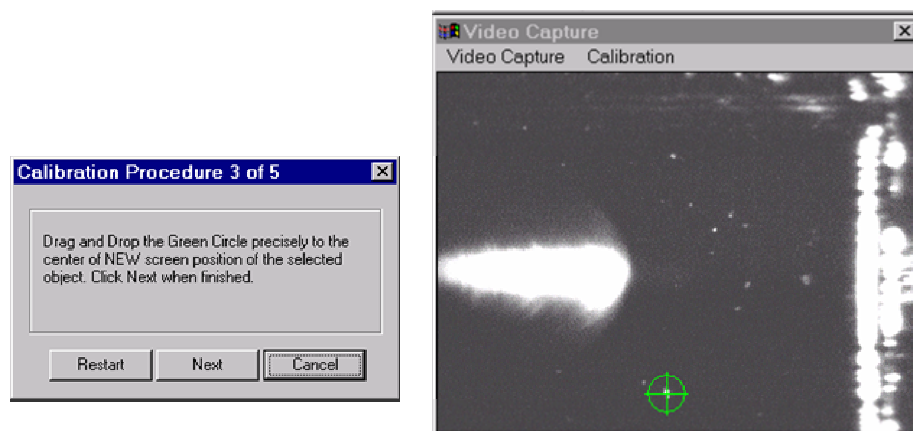

Fig. 7-9b Step 3 of the Video Capture Sample Positioning Calibration showing the green target dragged and dropped back on top of the visually distinct object.

In Step 4 (Fig. 7-10), the target plate the target plate moves again. This time it moves vertically. Watch where the visually distinct object moves to. Drag and drop the green target icon to the same visually distinct object. Then click “Next”.

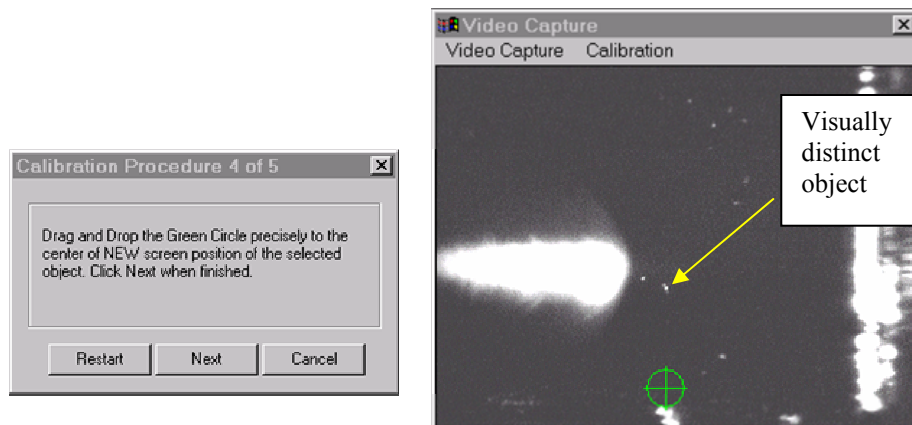

Fig. 7-10a Step 4 of the Video Capture Sample Positioning Calibration showing the visually distinct object moved *vertically* away from the green target.

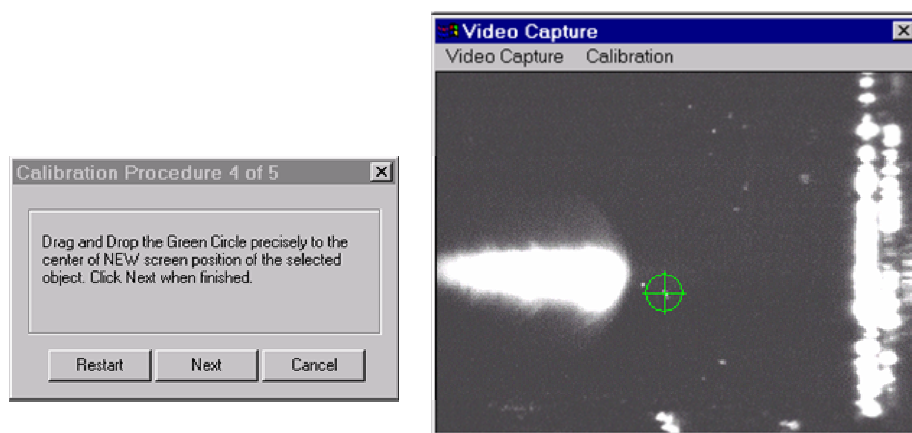

Fig. 7-10b Step 4 of the Video Capture Sample Positioning Calibration showing the green target dragged and dropped back on top of the visually distinct object.

In Step 5 (Fig. 7-11), click “Finish” to accept the new calibration. “Cancel” keeps the original calibration. “Restart” allows the user to recalibrate the system again.

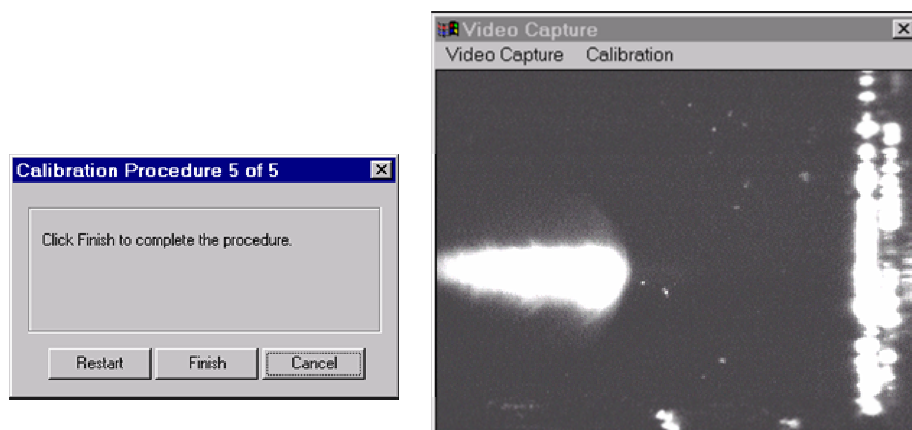

Fig. 7-11 Step 5 of the Video Capture Sample Positioning Calibration.

Now use the mouse pointer and double-click the left mouse button to verify that the sample moves to the desired location.

7.5 Running AP/MALDI on the LC/MSD instrument.

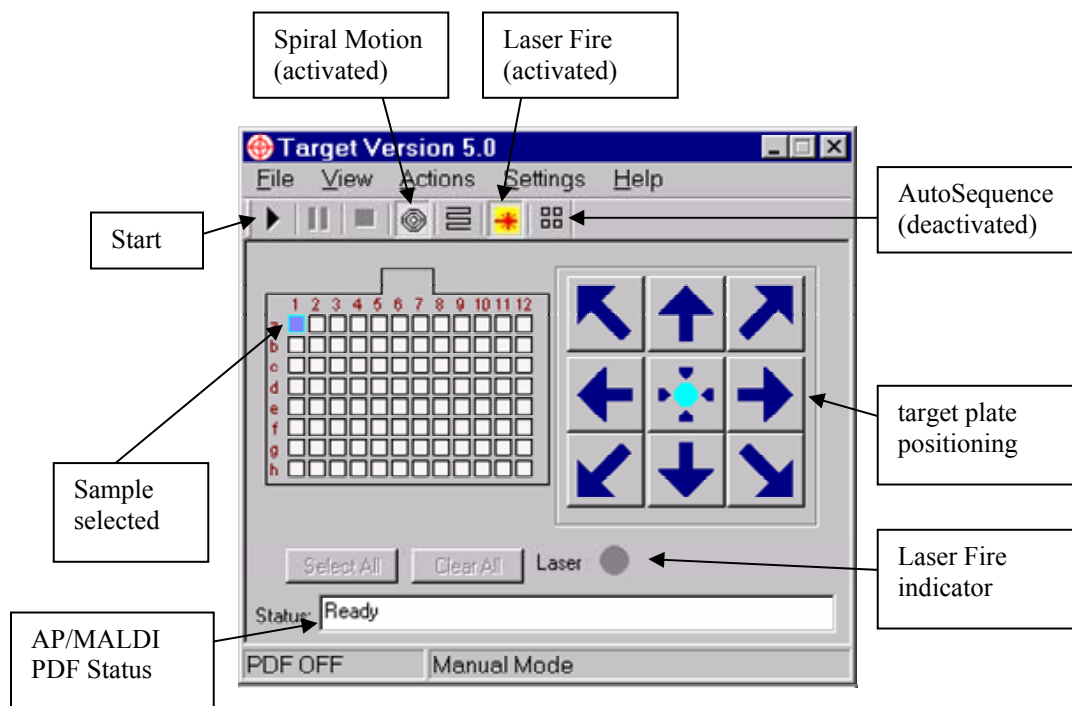





Fig. 7-12. Target software controls.

There are two modes of operation for the Target software: Manual (AutoSequence toolbar icon is deactivated) and AutoSequence. Switch between the modes by pressing the AutoSequence toolbar icon  (Fig. 7-12). In manual mode, only one sample on the "Target plate" can be selected. Click any spot in the Target Plate field and the target plate will move to the selected position. You can shift the position of the spot by clicking the arrow buttons placed around the Center button (See Fig. 7-12) or holding down on the arrow buttons to advance faster. Click the Center button to restore the central spot position.

In AutoSequence mode, multiple samples can be pre-selected. Use the ClearAll/SelectAll Buttons to select/clear all spots. To select a continuous series of spots, click the first spot, then pressing SHIFT, click the last spot; to choose selected spots, press CTRL and click the spots you want to select.

To start actions, press the "PLAY"  icon. The PLAY button also activates other features depending on what other toolbar icons (AutoSequence/Laser Fire/Spiral/Raster Motion) are activated. To stop ALL activated actions, press the "STOP"  icon.

Note, that even AFTER the actions are started (i.e., PLAY has been pressed), you can manually shift the spot by clicking on the Video Capture image. You can additionally switch the Laser ON/OFF and start/stop spiral motion by activating/deactivating the appropriate button.

In AutoSequence Mode, after the PLAY button is pressed, the target plate moves to the upper left of the selected spots. Then the laser starts firing and the target plate spirals slowly around the initial position (if the default spiral and laser fire buttons are used (i.e. activated)). After a pre-selected time, all actions stop and the target moves to the next pre-selected spot. Again, the laser starts firing and the target plate spirals slowly around the initial position (if the default spiral and laser fire buttons are used (i.e. activated)). The process is repeated until the last spot is finished (or the STOP button is pressed). The order of sample testing is from left to right in every row, from top to bottom rows. Additional time delays can be introduced between the samples and between the rows.

To change various program parameters like, spiral/raster motion properties, laser frequency, AutoSequence Mode timing and so on, click the "Settings" button and edit the parameter(s) as it is shown in Figs. 7-13 to 7-15, below.

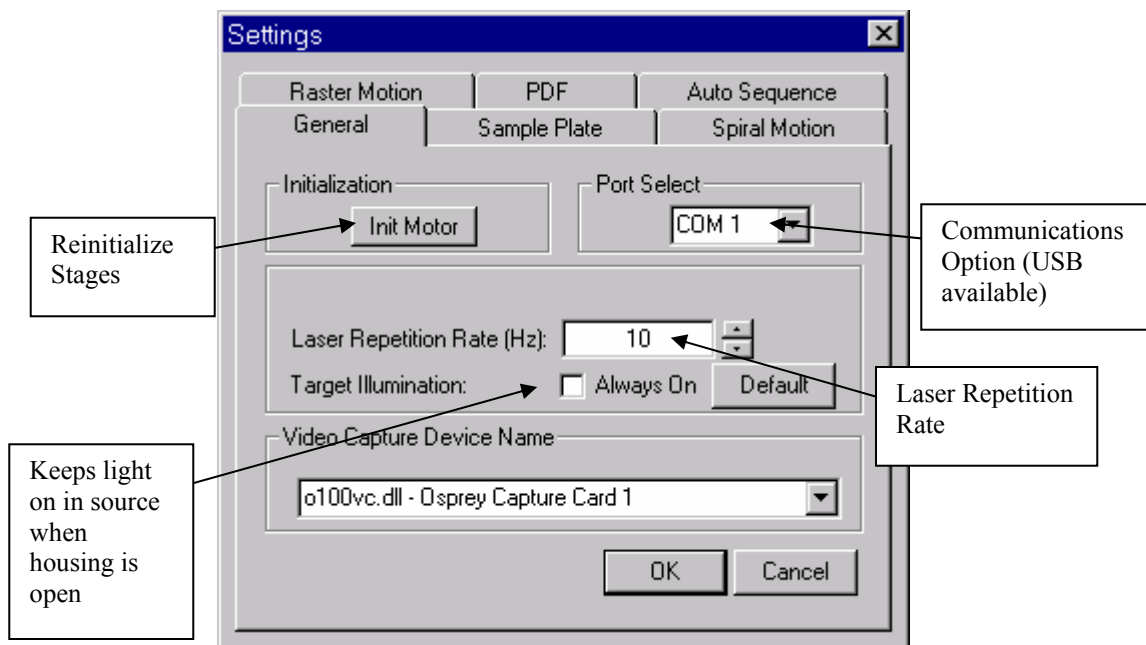

Fig. 7-13 General settings in the Target software.

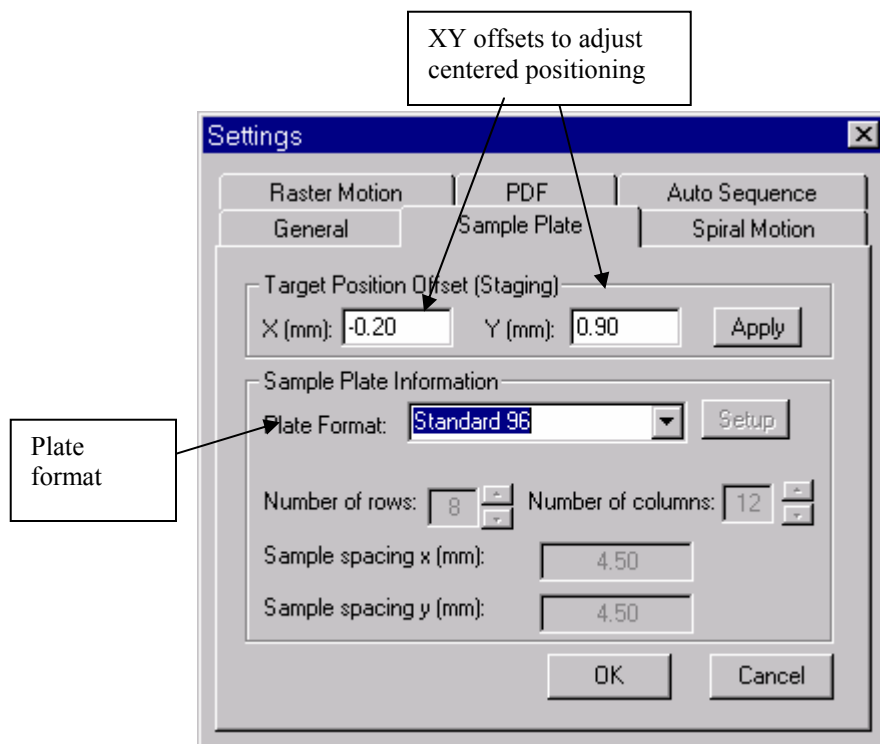

Fig. 7-14 Sample Plate settings in the Target software.

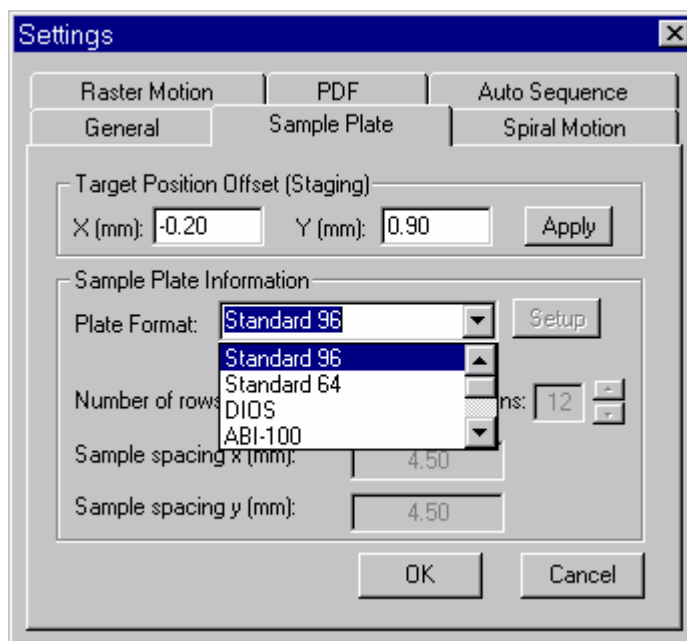

Fig. 7-15. Plate formats supported by Target version 5.0 and the AP/MALDI PDF ion source

After you have finished hardware/software installation, sample preparation, and successfully run the Target software, everything is ready to operate the LC/MSD instrument in AP/MALDI mode.

7.6 *Setting the LC/MSD Parameters*

To run AP/MALDI on the LC/MSD instrument optimally, the following tuning procedure of the LC/MSD Trap Control program is recommended:

- Autotuning the instrument in ESI mode before switching the source to AP/MALDI and saving the corresponding tune-file is a good idea. See the LC/MSD Operator's Manual.

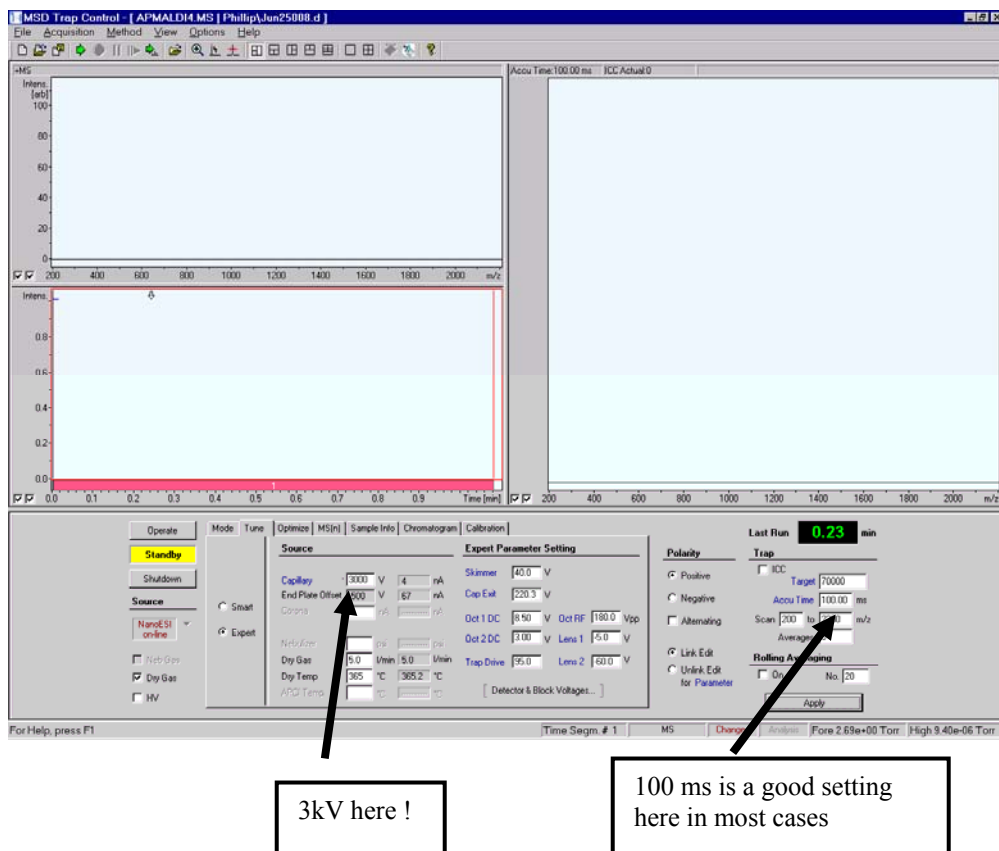

Fig. 7-16 Good parameters for the capillary HV (3000 V) and Accumulation time (100 ms) in the ion trap are shown above.

- The AP/MALDI PDF source typically generates a much weaker ion current compared with Electrospray. So it is recommended that you increase the Accu Time to 100-200ms or even more. If ICC is OFF, you are responsible for decreasing the Accu Time manually for samples with higher analyte concentration to avoid Trap saturation.
- **Drying gas and nebulizing gas settings:** The drying gas, usually nitrogen, is used to evaporate the clusters formed during the MALDI process. It enters the ion formation region and flows around heating the capillary extension. The gas is typically heated to 180°C to 365°C at a flow of 3-8 liters/minute. Because there is no need for nebulizer gas for AP/MALDI, it is recommended that you set the source settings in the LC/MSD control to nanoESI.
- Laser pulse energy may be easily tuned at the front panel of the Control Unit by using the Attenuator handle (see Fig. 5-1). This handle has a scale; its position can vary from 1 to approximately 12 (mm). The rotation of the handle changes the position of the lens that focuses the laser beam to a fiber surface. 12 (mm) corresponds to complete focusing conditions (that is, maximum pulse energy). Lens motion is limited to approx. 12

- (mm) to avoid fiber surface damage. Typically you should tune the attenuation for the maximum signal only once for every matrix type (α -CHC, DHB and so on).
- The final recommendation is how to choose between manual and spiral/raster target motion control in the **TARGET** program. Typically, the signal from one spot deteriorates in 5-20 seconds (depending on the matrix, sample preparation, and laser attenuation). The target can be shifted manually to another spot within the same sample; but manual target motion will produce an ion signal that is unstable over the acquisition time. If you need a long and stable signal, start the laser firing and then start either of the predefined target motion patterns of spiral or raster. This mode will enable you to continuously expose fresh parts of the sample to laser irradiation. Spiral motion will give you a stable AP/MALDI signal for 10-20 minutes. It is sufficient for MS, MS/MS, and MSⁿ experiments.
 - Fig. 7-17 represents a screen copy made during an AP/MALDI spectrum measurement of α -CHCA matrix. You can easily switch between the *MSD Trap Control* and *TARGET* programs to operate both the LC/MSD and AP/MALDI PDF source from the same computer. Or alternatively, separate computers can be used to run *TARGET* software and operate AP/MALDI.

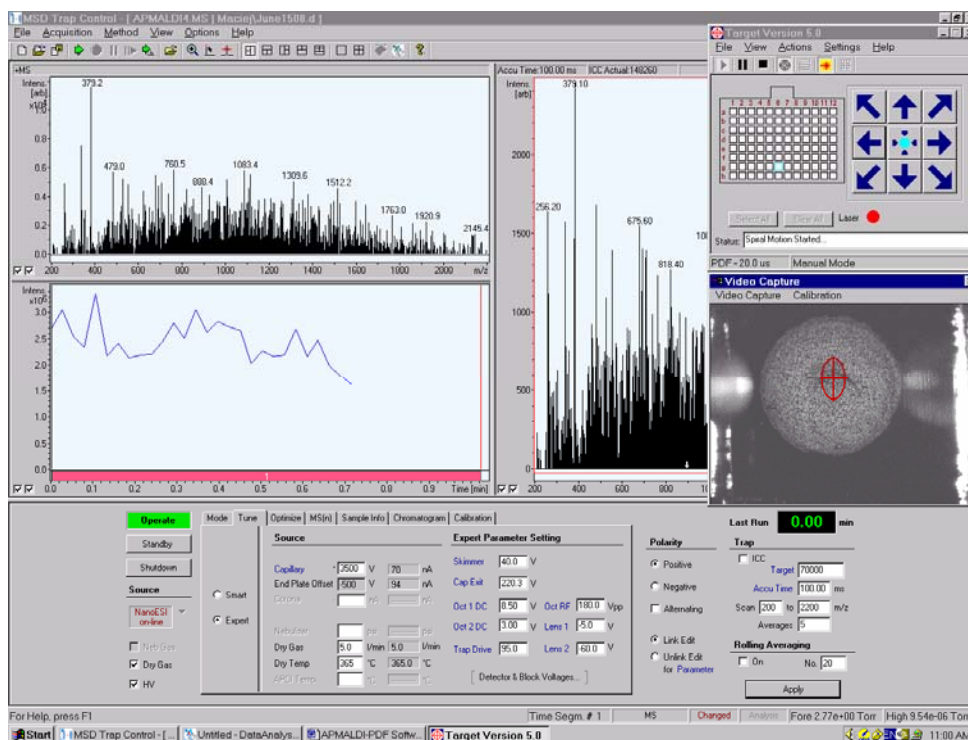

Fig. 7-17 Operation of Target software on the LC/MSD instrument computer.

7.7 PDF Operation

The PDF technology, integrated into the ion source holding, allows the user to adjust the delay time interval before the electric field is removed from the AP/MALDI ion source. The delay time interval is controlled by typing in a value in the “Pulse Delay” box in the “Settings” menu (this is the *delay* time before the electric field between the Target Plate and capillary is rapidly *pulsed* to zero) as shown in Fig. 7-18. This timed interval is also later displayed in microseconds on the lower left-hand corner of the Target operating software.



Figure 7-18. Pulse Delay adjustment

To achieve the best performance from applying the PDF technique, the user should first operate the PDF in the “OFF” mode by unchecking the PDF box (Fig. 7-18 shows PDF box checked ON). A standard peptide at 100 fmol level can be used to tune the AP/MALDI PDF setup (see sample preparation procedures (Section 6)).

Record the spectrum from classical AP/MALDI operation, making note of the signal level. Change the HV on the Tune page of the LC/MSD software, so that the “Capillary Voltage” is increased from classically 3.0kV to 3.5kV.

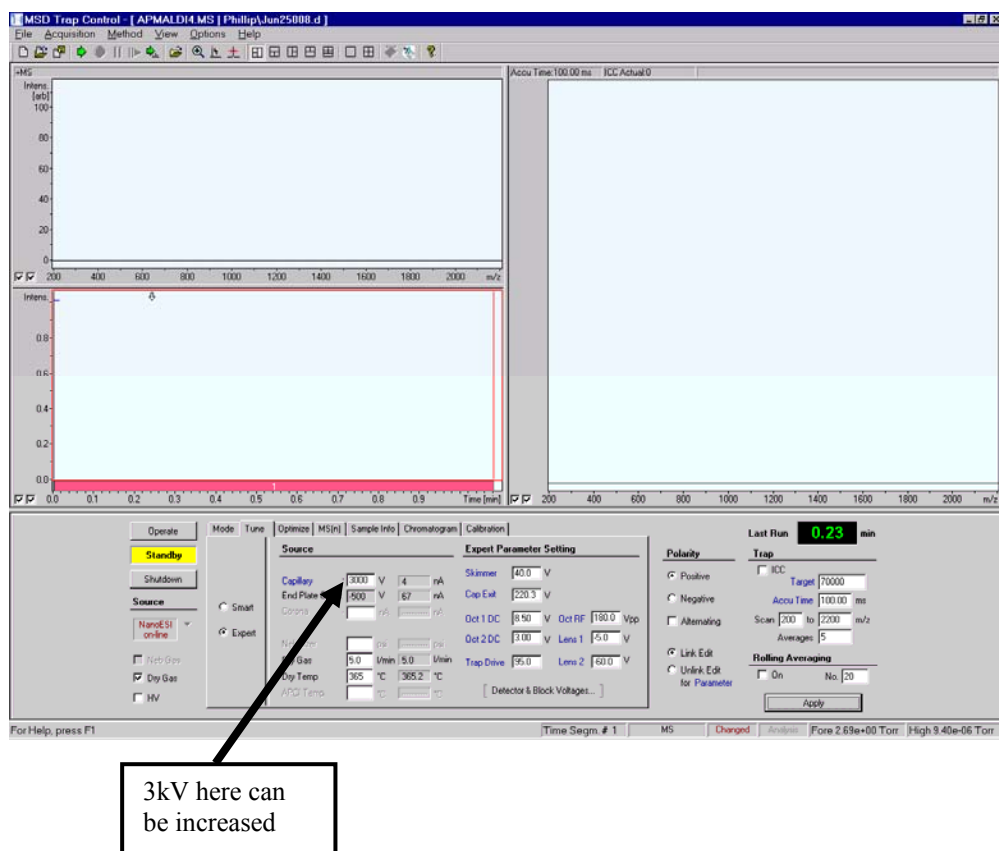

Figure 7-19. Capillary high voltage typically set at 3000V may be increased for PDF.

Adjust the Pulse Delay to around 20 microseconds, and adjust it +/-15 microseconds to determine the time for the highest signal level. You can confirm that the PDF is operational by switching the Pulse Delay time to 1 μ s which should show a dramatic drop in ion signal. This is correct because there is virtually no electric field to transport ions to the MS inlet with such a short Pulse Delay time. When the Pulse Delay is too long (for example >200 μ s) ions will have already entered into the MS inlet. Thus there is optimal Pulse Delay time. Once determined, this should not need to be changed.

To further enhance the throughput of the AP/MALDI PDF setup, de-focus the UV laser by loosening the set screw and pushing in the focusing tube on the ion source about 1-2mm (Fig. 7-20). There is a scale on the side of the focusing tube to facilitate this adjustment.

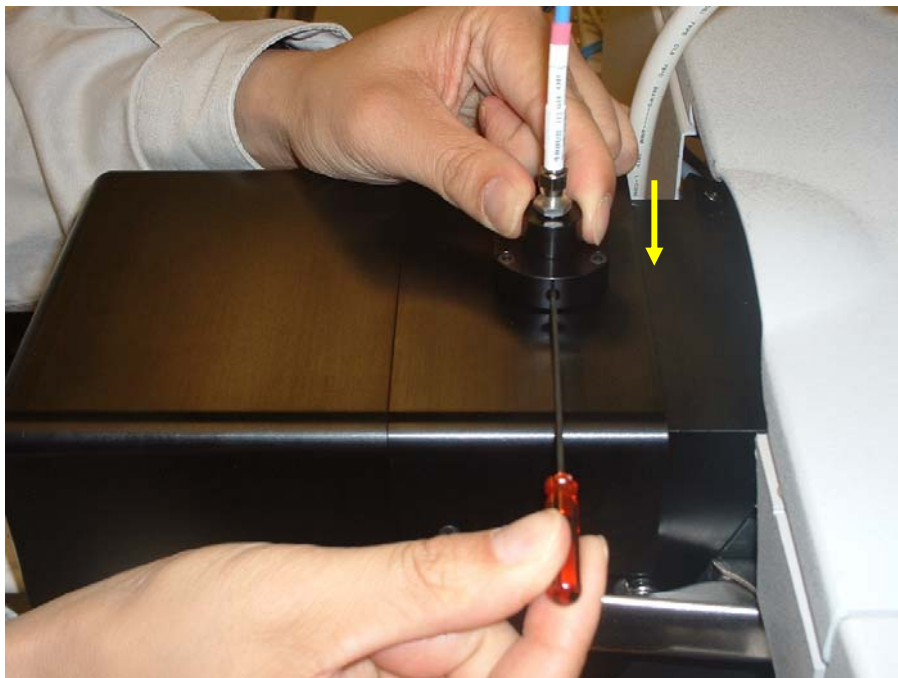

Fig. 7-20. Adjustment of the focusing tube on the AP/MALDI ion source to defocus the laser beam.

Then increase the laser energy on the AP/MALDI PDF Control Unit (Figure 7-21) so that roughly the same laser fluence (energy/area) is maintained. The purpose behind this exercise is to generate more analyte ions per laser shot. With the PDF Technology, ions generated far away from the MS entrance can even be entrained into the MS.

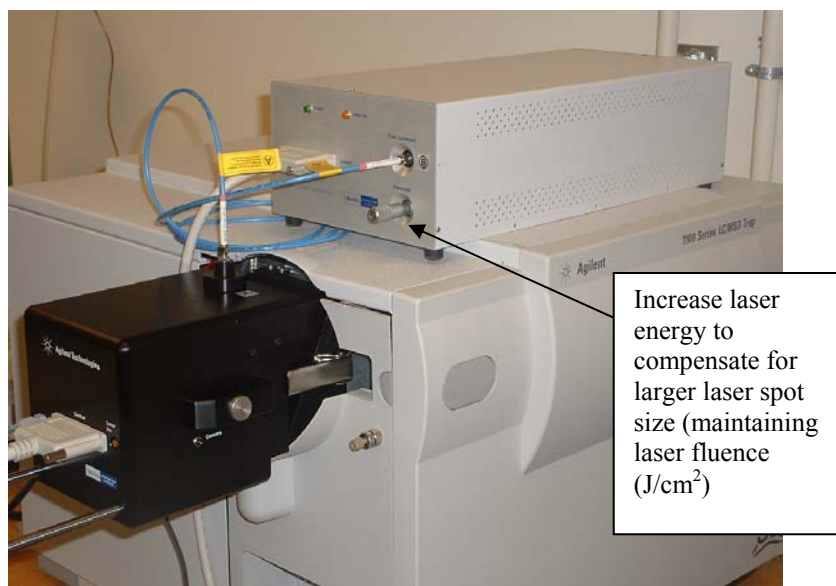

Fig. 7-21. Increase laser energy on the AP/MALDI Control Unit.

Similar to the operation for optimizing the Pulse Delay, tune the focusing tube position and the laser energy, while optimizing the signal intensity for a standard chemical. AP/MALDI is sensitive to the laser fluence. If the fluence is too high, there can be increased chemical noise, and poor analyte S/N. If the fluence is too low, analyte peaks may not be present due to insufficient ionization energy. Carefully adjust the laser energy and laser focusing until the signal is optimal. An improvement in signal intensity by a factor of an additional 2 to 3 is reasonable in these laser-related adjustments.

7.8 *Manual Mode of Operation*

Manual control means that you control the data acquisition in an interactive real-time manner. Most of the acquisition parameters can be accessed and changed during the data acquisition using the *MSD Trap Control* and *TARGET* features. The data acquisition in *MSD Trap Control* is started independently from the target position and laser control in the *TARGET* software. The spectra acquired will depend on what sample is currently located near the inlet capillary and what parameters (like laser frequency and energy, speed of motion of the target plate accessible via *TARGET* software, or voltage on the capillary, octopole and ion optics voltages, etc. accessible via *MSD Trap Control*). Saving the spectral data is your responsibility and is done using appropriate *MSD Trap Control* functions.

The procedure for operating in manual mode consists of several basic steps:

1. Deactivate the “AutoSequence” button in the *TARGET* software window (See Fig. 7-12 for location of AutoSequence button).
2. Start data acquisition using the *MSD Trap Control* software (see the previous *Setting Parameters* section (Section 7.5) in this manual or Agilent’s *MSD Trap Control* software manual for details).
3. Set desired *TARGET* settings (using the Settings dialog window). Set the desired laser energy (using the micrometer knob on the Control Unit front panel), activate the “Laser Fire” button and “Spiral Motion” button (if desired) and PDF (if setup/desired).
4. Click on the desired sample using the sample spot selector (map) provided in the *TARGET* software window (see Fig. 7-1). The target plate will move to this sample position and stop near its center (this is observable on the Video Capture imaging system).
5. Press the PLAY button in the *TARGET* software window to start AP/MALDI operation (and PDF if activated).

6. Adjust the desired laser energy (using the micrometer knob on the Control Unit front panel), or position the laser spot on the sample (using the “Point-and-Click” sample positioning system or the “Manual Motion Control” arrow buttons in the *TARGET* software window while observing the sample on the Video Capture screen).
7. Save data acquired, when necessary, using *LC/MSD MSD Trap Control* software.
8. Press the STOP button in the *TARGET* software window to stop AP/MALDI operation.
9. Repeat steps 3-8 to acquire one more spectrum from the same or another sample.
10. Stop data acquisition on the LC/MSD.

7.9 Automated Mode of Operation

This mode of operation requires a special “External control cable” for connecting the AP/MALDI’s “External Control” connector on the Control Unit rear panel with the LC/MSD’s “Remote” and “Aux Port” connectors. Synchronization of the LC/MSD and AP/MALDI PDF source operations is achieved via bi-directional signal communication between the LC/MSD and the AP/MALDI PDF Control Unit electronics. In this mode of operation the data are acquired in automated (unattended) mode by you selecting a sample pattern on the sample map in the *TARGET* software window which then moves the target plate sequentially from one sample to another sample according to the sample map you’ve selected.

In this mode the *TARGET* software initiates the LC/MSD’s data acquisition process and turns on the laser firing; then, the LC/MSD tells the *TARGET* software when it finishes the acquisition of the data from the current sample. The *TARGET* software turns off the laser, moves the plate to the next sample position, and this process starts over again until the last sample is finished. For proper operation in this mode it is important to do things in this order: first select the LC/MSD Operate mode and then start the *TARGET* software operation.

The settings for the AutoSequence can be found in the Settings menu and are shown in Figs. 7-22 and 7-23. Internal timing is used when the AP/MALDI PDF Control Unit changes sample spots and performs AP/MALDI PDF while the LC/MSD instrument continuously acquire data (a single file for multiple samples). External timing is used when the AP/MALDI PDF Control Unit sends out start commands to the LC/MSD trap, and acquires mass spectra in separate files (one file for each sample).

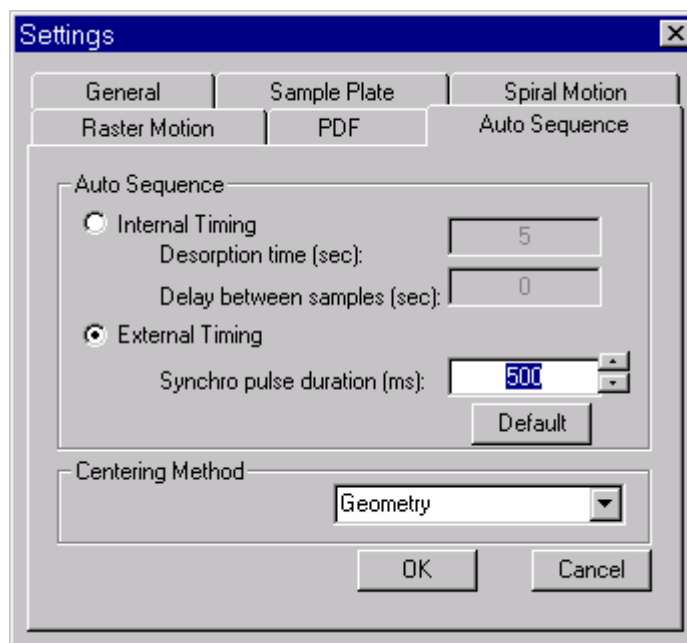

Fig. 7-22 Auto Sequence settings

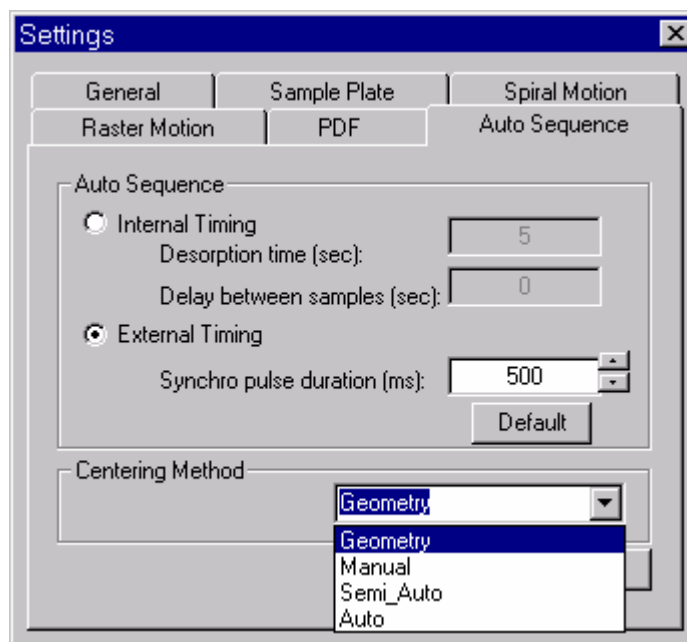

Fig. 7-23 Auto Sequence modes.

Different modes of AutoSequence are available and include: Geometry, Manual, Semi-Auto, and Auto. These modes are used to determine the center position of samples on a target plate.

Geometry mode is used when the center of all sample spotted on a plate are precisely in the same spot in each sample cell. This is useful for automated, precisely controlled spotters.

When manually hand spotting of samples is conducted, there are three modes of automated analysis that may be useful. Manual mode is used to allow the user to tell the Target software where the sample center is for each spot to be analyzed. Semi-Auto mode is used to allow the computer to apply image-recognition software that determines the sample center, but requires verification from the user as to the accuracy of the chosen center. Finally, Auto mode enables the computer full image-recognition of the center of each sample, and ensuing analysis.

Following is the procedure for operating in the Auto Sequence mode:

1. Using one supplied cable, **connect** the “External Control” connector on the Control Unit’s rear panel with the LC/MSD’s “Remote” and “Aux Port” connectors.
2. **Check** the “AutoSequence” button is activated in the main *TARGET* software window (see Fig. 7-14) and **check** the “External Timing” radio button in the *TARGET*’s “Settings Dialog” window (see Fig. 7-22).
3. Set other *TARGET* settings (using the Settings Dialog window). Set the desired laser energy (using the micrometer knob on the Control Unit front panel), press the “Laser Fire” button and “Spiral Motion” button (if desired) and set/activate “PDF” (if desired).
4. Select desired position(s) on the sample spot selector (map) in the main *TARGET* software window by first using the “Clear All” or “Select All” buttons in the *TARGET* software window and then depressing Shift or Ctrl keyboard buttons and clicking on the sample map. (Selecting sample spots is similar to using the mouse for file selection in standard dialogs of the Windows operation system. If the Ctrl button is depressed than clicking of the mouse button changes the selection to the opposite (to Selected if Not selected and vice versa). If the Shift button is depressed, then clicking of the mouse button will selects a contiguous group of samples). The “Clear All” or “Select All” buttons in the *TARGET* software window are there for convenience. The selected samples will be executed in the left-to-right order starting from the highest row on the map and then moving to the next lower row.
5. Click on the Operate button (turns green) in the LC/MSD Trap Control software.
6. Click on the PLAY button in the *TARGET* software window to start AP/MALDI (PDF) operation. The data acquisition will start and continue during the time specified for the segment. When the data acquisition from the first sample is done, the laser firing is stopped and the target moves to the next sample spot. The process will be repeated until the last sample

spot has been analyzed. The sample positions on the map where the data have been collected are shown by a solid color. The *current* sample is indicated by a blinking color.

8 MAINTENANCE —TROUBLESHOOTING THE SOURCE.

Maintenance and troubleshooting: The AP/MALDI PDF source does not require regular maintenance, except for the cleaning of the optical fiber cable ends every six weeks. (Section 8.5 of this manual describes a cleaning procedure). Please refer to Section 5.3 of this manual for instructions about connecting and disconnecting the optical fiber. It is strongly recommended that you follow the troubleshooting procedures that are described below.



DO NOT ATTEMPT services or repairs that are not covered in this Troubleshooting section. For services and repairs beyond those specifically provided in the Troubleshooting section, contact the manufacturer, MassTech, Inc. 6992 Columbia Gateway Dr, Columbia, MD, 21046 (443)539-1758

The AP/MALDI PDF source is supplied completely tuned and ready for operation. Still there are several reasons why the MS signal might decrease significantly or even disappear at times. The following sections describe possible symptoms with their remedies



Remember: any contamination of the optical fiber's opened ends results in irreversible fiber damage during the source operation. Get in the habit of putting the protective plastic caps back on the optical fiber ends immediately after you disconnect the optical fiber from the source and Control Unit. If by accident you touch (or contaminate) the opened ends of the fiber, clean it according to the procedure in Section 8.5. It is recommended that you clean the fiber ends every six weeks to avoid deposit accumulation (preferably using the method described in Section 8.5).

8.1 PROBLEM: Insufficient ion production - lack of laser power being delivered to the target spot.

1. To test for a lack of laser power hitting the target spot, prepare several target spots with a dense α -CHCA matrix. (α -CHCA provides the brightest fluorescence and the lowest pulse energy necessary.)
2. Set the attenuation to full laser power. (e.g., 10-11mm).
3. Fire the laser and watch the computer's Video Capture screen.
4. If you can see a blinking spot on the computer's Video Capture screen, see if the matrix crystals at that spot are disappearing. (For α -CHCA matrix without the beam attenuation the crystals should disappear in 5-15 seconds). If they disappear, then laser power is sufficient.
5. If they don't disappear in 5-15 seconds at the blinking spot, then laser power is NOT sufficient.
6. If the laser power is NOT sufficient, you have three options
 - i. Try another optical fiber (one spare was shipped with your unit).



IMPORTANT: If you choose to replace the optical fiber, turn the power OFF on the Control Unit.

- ii. Try to improve the focus of the laser beam on the target. To do this, attempt to adjust the position of the source fiber connector with respect to the source housing as described in Section 8.2
- iii. Try to improve the position of the laser beam relative to the inlet Section 8.3

If these actions do not help, call MassTech for assistance.

8.2 **PROBLEM:** *The laser beam is not well-focused*

Goal: To increase the laser fluence, i.e. energy per unit area (J/cm^2) of the irradiation spot by adjusting the laser spot size.

1. Locate the Allen screw on the fiber optic mounting connector, as shown in the photo below.

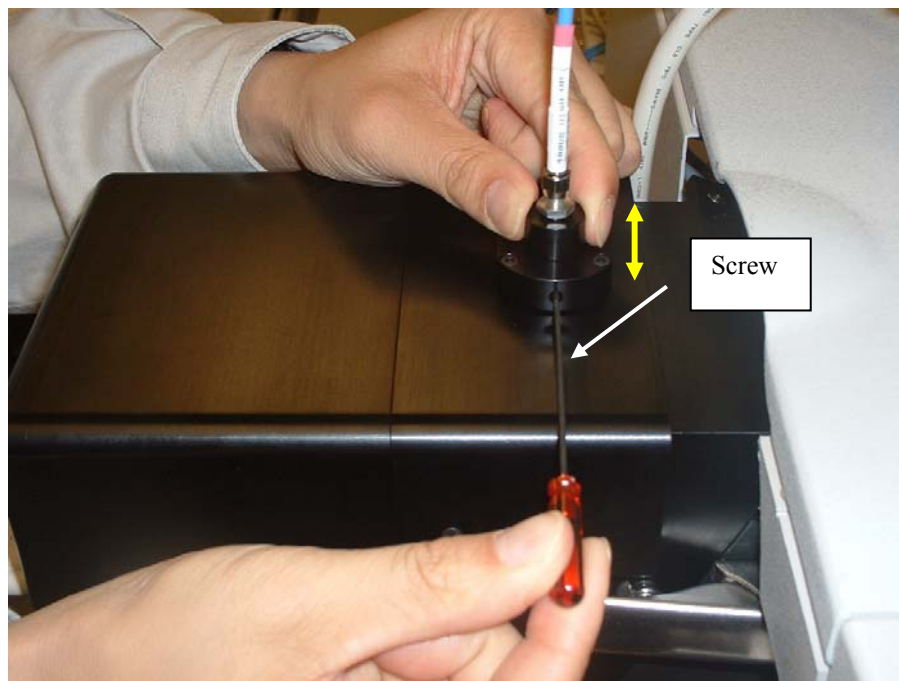

Fig. 8-1. Adjusting the laser focusing by moving the fiber optic connector up or down.

2. Loosen the screw; notice that the fiber optic connector can now be moved up and down.
3. Push the fiber optic connector down about 1 or 2 mm (Fig. 8-1).

4. Disable the spiral/raster so that the laser light strikes the same spot each time.
5. Start the laser firing at maximum power.
6. Using the camera, you will be able to see how fast the matrix desorbs.
7. If the spot does not desorb quickly, pull the fiber optic cable up 1 or 2 mm and repeat the experiment.
8. Once you see that the matrix is desorbed in less than a minute, screw in the Allen screw to relock the position of the fiber optic cable.

8.3 PROBLEM: The laser beam focal point at the target plate is not aligned with the capillary extension.

The goal of this procedure is to improve the source's sensitivity by aligning the laser beam focal point at the target plate surface with the Capillary extension.

Safety: The procedure is performed from outside the source housing with the source closed. The position of the laser beam is monitored on the Video Capture screen. As a result, the **procedure is safe** and can be performed with both the LC/MSD instrument and AP/MALDI PDF source switched ON.

Step 1. First, you need to determine if the laser spot is misaligned or not. Prepare several target spots with 1-2 μL of undiluted matrix (it could be either pure matrix solution or matrix/any analyte mixture). After drying, insert the target plate into the source, close it, switch it ON (if it was not switched before) and run the Target software (if this was not done already). Choose any empty (blank) target position. The picture on the Video Capture screen should look as follows (Fig. 8-2):

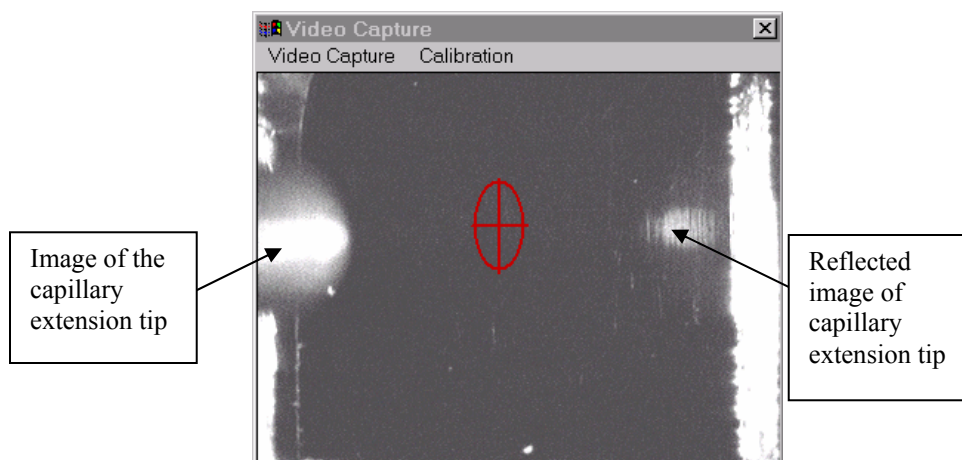

Fig. 8-2 Blank sample spot on the Video Capture screen

Both the capillary extension tip image and its reflection are not well-focused; to ensure that you identify the images correctly, just move the target in any direction with the arrow keys of the Target program. The images of the capillary extension tip and its reflection are still, while the image of the target plate moves.

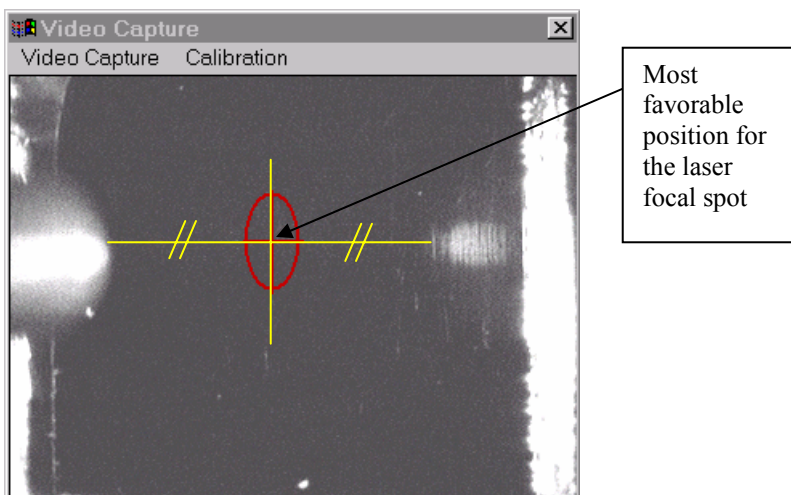

Fig. 8-3 Ideal laser positioning, on-axis with the capillary extension.

The **ideal** position for the laser focal spot on the target surface plane is at the middle of the imaginary line that connects the image of the capillary extension tip and the image of its reflection (see Fig. 8-3). Now we need to determine the **real** position of that spot.

Move the target plate to a position where a matrix was deposited. Now the picture at the screen should look like the following:

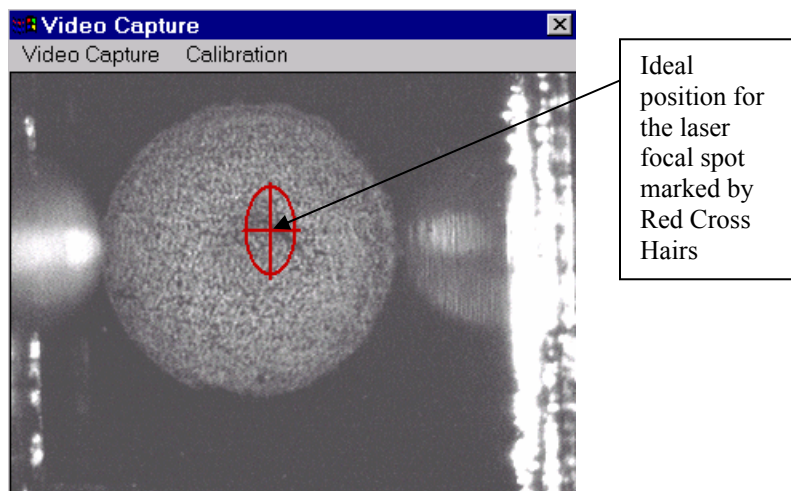

Fig. 8-4 Image of matrix crystals

Step 2. Switch ON the laser, spiral/raster motion OFF. Set the maximum laser power with the attenuator screw. Now you should see the matrix crystal's evaporation at the place where the laser beam is focused (Fig. 8-4)

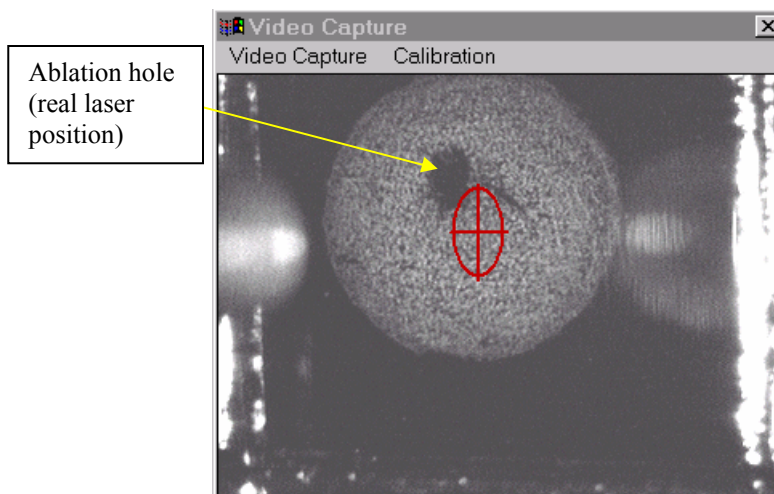
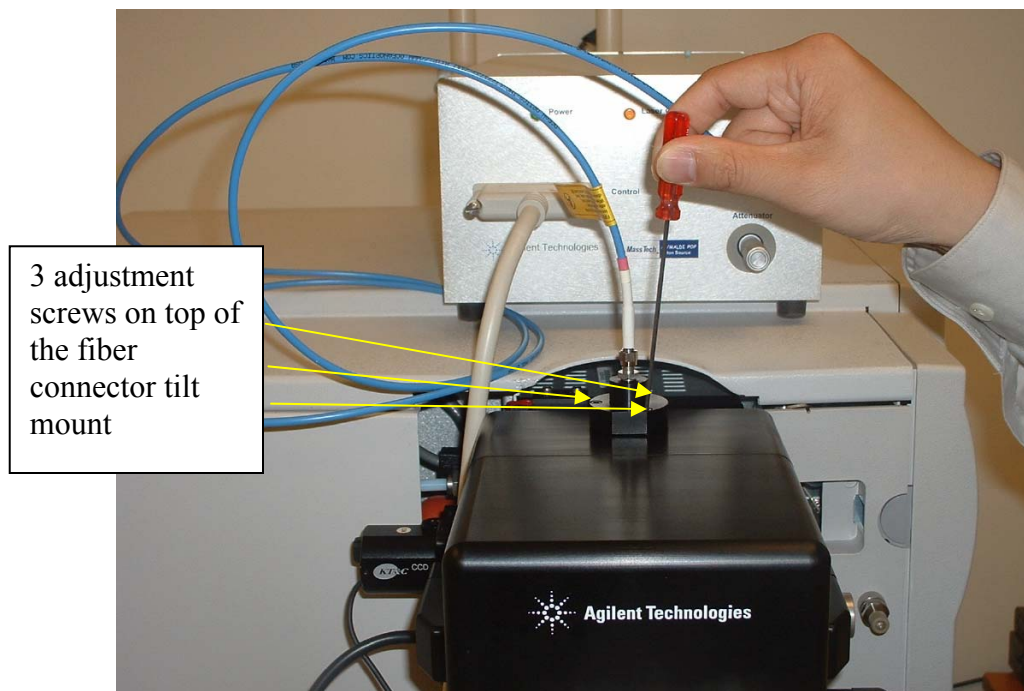

Fig. 8-5 Ablation of the matrix sample away from the ideal laser position.

By comparing the location of the ablation hole with the ideal position shown by the Red Cross-Hairs, we can see that the laser focus is close to its ideal position, but slightly above and to the left. The deviation of the focal point shown in Figures 8-4 and 8-5 is acceptable, especially with PDF activated, but the source sensitivity can possibly be improved by fine tuning.

Step 3. Continue with the same spot. Switch ON the laser at maximum power (minimum attenuation). Using a hexagonal screwdriver, turn the three screws (see Fig. 8-6).

Look at the Video Capture screen for the corresponding motion of the laser focal spot. Your objective is to move that spot as close as possible to its ideal position at the middle of the imaginary line that connects the image of the capillary extension tip and the image of its reflection (see Fig. 8-3). The position in Fig. 8-7 below is a good alignment.



3 adjustment screws on top of the fiber connector tilt mount

Fig. 8-6. Adjustment of the Laser position by tightening/loosening screws on the fiber connector tilt mount.

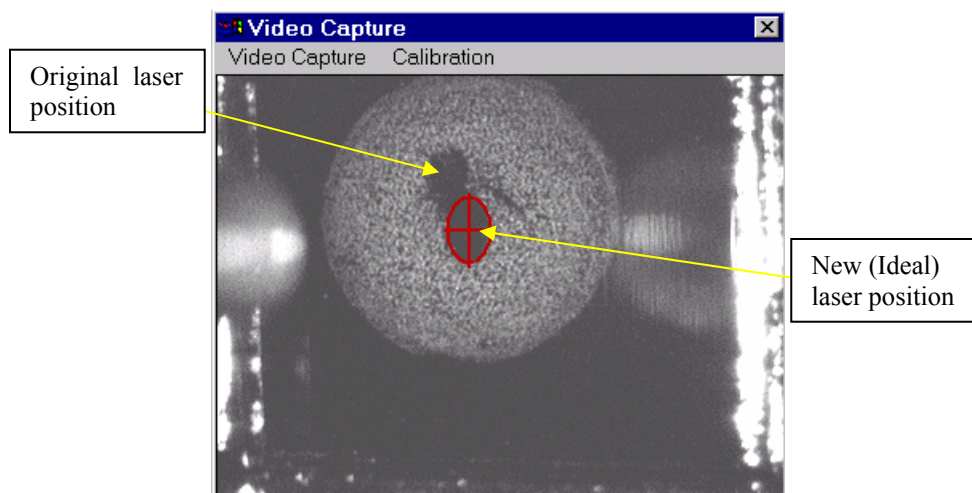

Fig. 8-7 Good alignment of the laser position.

Now you can set the best attenuation, appropriate for your matrix, shift the target to a new fresh spot and prove that the sensitivity is better. Alternatively, the position of the laser focal spot can be adjusted by a rotation of tuning screws (Fig. 8-6) based on the quality of the MS signal by a trial-and-error method.

8.4 PROBLEM: the Ion transport into the LC/MSD instrument is clogged/blocked.

Goal: Determine if ion transport path to MS is blocked

1. To test for clogged ion transport into the LC/MSD instrument, prepare several target spots with a dense α -CHCA matrix. (α -CHCA provides the brightest fluorescence and the lowest pulse energy necessary.)
2. Set the attenuation to full laser power. (e.g., 10-11mm).
3. Fire the laser and watch the COMPUTER screen.
4. If you can see a blinking spot on the COMPUTER screen, see if the matrix crystals at that spot are disappearing. (For α -CHCA matrix without the beam attenuation the crystals should disappear in 5-15 seconds). If they disappear, then:
5. Ensure that the LC/MSD interlock is operating properly.
6. Ensure that the LC/MSD Trap Control program is configured as described in this Manual.
7. Ensure that your probe preparation & matrix material are being used properly.
8. If all the above are checked, the system should show at least spectral noise. If there is no chemical noise, the capillary may be clogged and require cleaning with a thin wire.
9. Finally, ensure that your LC/MSD instrument operates properly with the electrospray instrument attaches. The problem may be with the LC/MSD instrument rather than the source.

8.5 **PROBLEM:** *The optical fiber ends need to be cleaned*

It is vital that the cleanliness and surface quality of the fibers be maintained during the life of the product in order to ensure optimal performance. ***The optical fiber end protective caps should be used for cable protection anytime the optical fiber is removed from the operational position.*** One spare optical fiber cable has been shipped with your source.

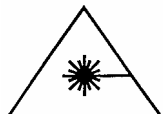

IMPORTANT: Whenever the optical fiber is being detached from or connected to the Control Unit or the Source housing, **MAKE SURE the power switch on the Control Unit is OFF.**

Materials required for Cleaning the Optical fiber ends:

1. Lint-free lens tissue (e.g., from Edmund Industrial Optics, Barrington, NJ, Stock No L60-375)
2. Spectroscopic grade alcohol-based lens cleaner (e.g., Edmund's Stock No. L53-881)
3. Powder-free gloves for handling optical components (e.g., Edmund's Stock No L54-808)
4. An optional Inspection microscope, 50x to 100x is typical strength.



While the exposed fiber ends are handled, gloves must be worn at all times.

1. Prior to cleaning the fibers it is advisable to inspect the fiber ends for damage or burn areas using a microscope.
2. Inspection of the fiber should reveal a uniform, bluish, smooth and shiny surface (maybe, with minor scratches, inclusions or dust particles).
3. After inspection, the fiber ends should be cleaned by one (or all) of the four methods described below, as needed to achieve the desired results.

(1) The first method should be used to remove contaminants *not tightly bound to the surface* of the optical fiber. Put a single drop of the cleaning solvent near the center of a small piece of lens tissue and rub the fiber end slowly and steadily, moving either the tissue or the fiber until no more liquid remains at the point of contact between the fiber and tissue.

(2) The second method is similar to the first one except that the one end of the lens tissue strip (2-3 cm wide) is fixed to the desk edge by adhesive tape and the other end pulled away by hand from the desk edge to create tension along the tissue strip. This tension allows more force to be applied to the cleaned surface.

(3) The third method is to fold lens tissue to form a small wiper approximately 3-4 mm wide, which may be trimmed as necessary; put 2-3 drops of cleaning solvent on the end of this “wiper” and gently draw across the fiber end surface. This method can be used to remove more tightly bound contaminants, but care must be taken with this method since it also applies more stress to the fiber ends. It is often advisable to inspect the progress of fiber cleaning process using the microscope.

- (4) A cleaning product called Fiberclean (made by HellermannTyton) has been included with your shipment. To use this product:
- i. Press the optical fiber end onto the Fiberclean tape and rub in figure 8 motions.
 - ii. After about three figure 8 motions, inspect the optical fiber end with a microscope.
 - iii. Repeat as necessary.
 - iv. Advance the tape after cleaning each optical fiber end.

8.6 PROBLEM: Spectral Response with high background and mass-shifted ion peaks

Because AP/MALDI PDF allows many more ions into the ion trap than does classical AP/MALDI, it is important to be aware of space-charge effects that can occur in the trap. It may be necessary to reduce the injection time of the ion trap to 100ms so as to not saturate the trap. An alternative way to solve this problem would be to adjust the Laser Energy attenuator so that fewer ions are generated.

We are ready to provide you any technical assistance! Call us at (443) 539 1758 or e-mail the problem to: msms@apmaldi.com

9 LITERATURE

1. Victor V. Laiko, Michael A. Baldwin, Alma L. Burlingame, "Atmospheric Pressure Matrix-Assisted Laser Desorption/Ionization Mass Spectrometry", *Analytical Chemistry*, Vol. 72, No.4, 2000, pp. 652-657.
2. Victor V. Laiko, Susanne C. Moyer, Robert J. Cotter, "Atmospheric Pressure MALDI/Ion Trap Mass Spectrometry", *Analytical Chemistry*, v.72, No.21, 2000, pp. 5239-5243.
3. Susanne C. Moyer, Robert J. Cotter, "Atmospheric Pressure MALDI", *Analytical Chemistry*, Sept 2002, pp. 469A-476A.
4. Phillip V. Tan, Victor V. Laiko, Vladimir M. Doroshenko, "Atmospheric Pressure MALDI with Pulsed Dynamic Focusing for High Efficiency Transmission of Ions into a Mass Spectrometer", *Analytical Chemistry*, v. 76, No. 9, 2004, pp. 2462-2469.

Additional References

Miller CA; Yi DH; Perkins FPD. "An Atmospheric Pressure Matrix-assisted laser Desorption/Ionization Ion Trap with enhanced sensitivity" *Rapid Commun. Mass Spectrom.* 2003, 17 (8): 860-868.

Moyer SC; Marzilli LA; Woods AS; Laiko VV; Doroshenko VM; Cotter RJ. "Atmospheric Pressure Matrix-assisted laser desorption/ionization (AP MALDI) on a Quadrupole Ion Trap Mass Spectrometer" *Int. J. Mass Spectrom.* 2003, 226(1); 133-150.

Doroshenko VM; Laiko VV; Taranenko NI; Berkout VD; Lee HS. "Recent development in atmospheric pressure MALDI mass spectrometry" *Int. J. Mass Spectrom.* 2002, 221(1):39-58.

10 WARRANTY INFORMATION – SIX MONTH LIMITED WARRANTY

MassTech, Inc. provides to the original purchaser the following limited warranty from date of invoice.

MassTech, Inc. warrants each AP/MALDI PDF instrument and its components to be free from defects in material and workmanship. Liability under this warranty covers servicing of the instrument when returned from the customer's facility within the United States pre-paid to our factory. MassTech, Inc. will repair any component(s) or part(s), except the optical cables, that it finds to be defective during the period of this limited warranty, which is six months from the date of invoice. Should a defect become apparent, the original purchaser must first notify MassTech, Inc. at (443) 539-1758 of the suspected defect and request a Return Merchandise Authorization number (RMA#). The instrument (or suspect components) should be carefully packaged in the original container (if the original shipping container has been lost, trashed, or damaged, another one must be purchased from MassTech, Inc. prior to shipping). Then, mark the original container with the RMA#, and ship prepaid to:

MassTech, Inc.
6992 Columbia Gateway Dr
Columbia, MD, 21046
Attn: Service Dept.

The instrument will be repaired in the shortest possible time and returned prepaid by the same shipping method as received by the factory. During the warranty period, no charge will be made to you for parts, service, or labor.

This limited warranty is void if the instrument has been damaged by accident, misuse, negligence, act of God, or serviced by any other person not authorized by MassTech, Inc. The warranty also does not apply to units that have had the serial lot number altered, defaced or removed.

This limited warranty contains the entire obligation of MassTech, Inc. and no other warranties expressed, implied, or statutory are given. No representative or employee of MassTech, Inc. is authorized to assume any further liability or grant any further warranties except as set herein.

MassTech, Inc. disclaims liability for indirect, incidental or consequential damages. Exclusion or limitation of incidental or consequential damages are not permitted by some states and this limitation or exclusion may not apply to you. Warranty rights vary from state to state; and, therefore, you may have other rights in addition to those provided by this warranty.

APPENDIX A THERMO LASER SCIENCE OEM 337-SI NITROGEN LASER SPECIFICATIONS

Part Number	337203
Wavelength	337.1 nm
Spectral Bandwidth	0.1 nm
Repetition Rate	Up to 10 Hz, user-supplied trigger
Pulse Width, FWHM	4 nsec
Pulse Energy	300 μ J
Pulse to Pulse Energy Stability	3% std. dev. at 10 Hz
Peak Power	75 kW
Average Power	3mW at 10 Hz
Beam Area	35 mm ²
Beam Divergence, Full Angle	0.3 mrad
External Trigger Input	TTL, opto-isolated
Trigger In to Optical Pulse Out	<1 μ sec, <40 nsec std. dev. Jitter
Power Requirements	+24 volts DC, 600 mA average at 10 Hz, <1 A peak
Power Consumption	15W at 10Hz
Dimensions, L x W x H	7.1 x 6.8 x 3.6 in; 18.1 x 17.4 x 9.2 cm
Weight	9 lbs; 4.1 kg

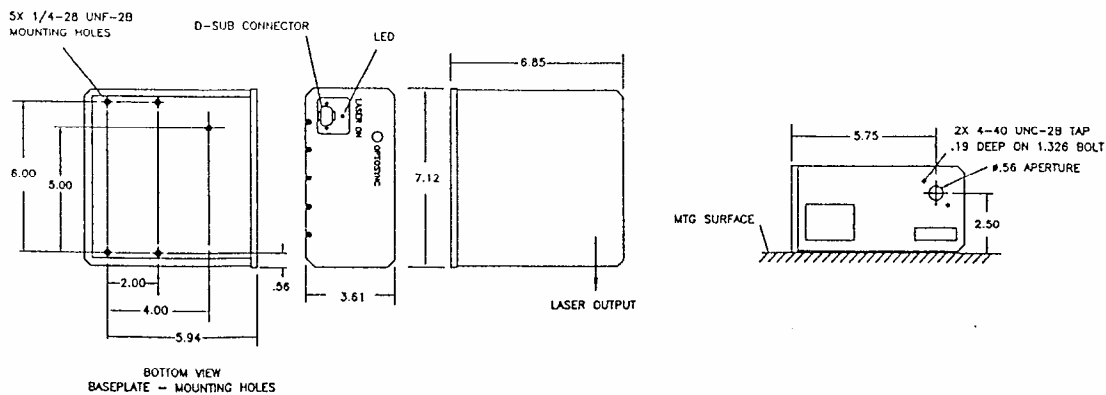

APPENDIX B ILLUSTRATION OF THE LASER ENERGY ATTENUATION CURVE

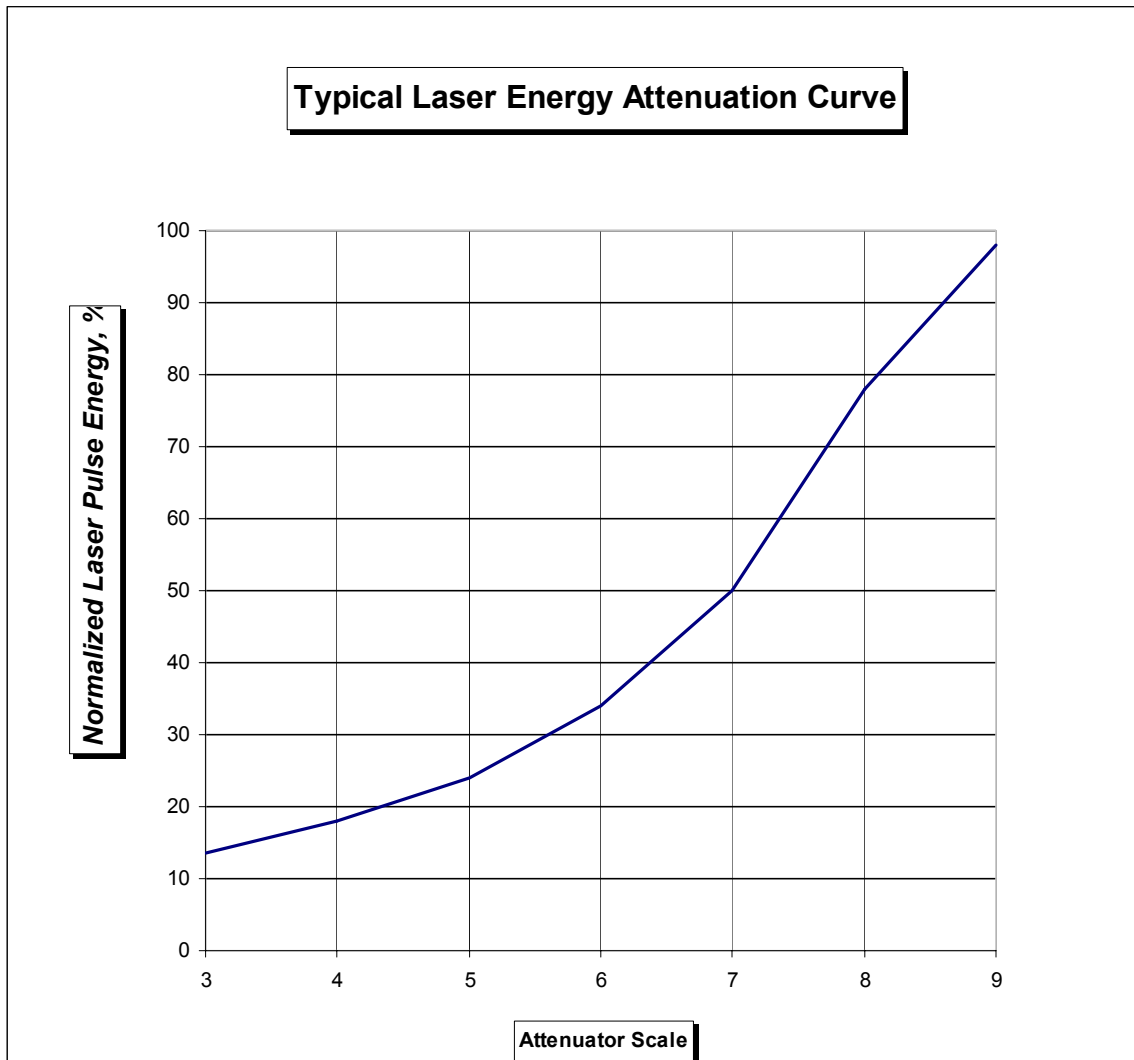

APPENDIX C WARNING AND IDENTIFICATION LABELS

Labels Concerning the Optical Fiber

These are the two Warning labels for each end of the optical fiber

A	TURN OFF the Power whenever the fiber is connected to or disconnected from the Control Unit or Ion source	FIRST, connect this end (A) to the Ion source, then connect the other end (B) to the Control Unit. When disconnecting this cable, first disconnect it from the Control Unit (B).	A
----------	---	--	----------

B	FIRST, connect the other end (A) to the Ion source, then connect this end (B) to the Control Unit. When disconnecting the cable, first disconnect this end (B) from the Control Unit	TURN OFF the Power whenever the fiber is connected to or disconnected from the Control Unit or Ion source	B
----------	--	---	----------

This is the Identification label to place on the Optical fiber ZIPLOC bag

Mass Tech AP/MALDI Ion Source
Part #110-AC0004 Optical Fiber cable
 ONLY replace with an exact replacement part:
 (Part # 110-AC0004 from MassTech, Inc.)
 Tel. 301-879-6994

The A and B below go on the Ion Source and Control Unit, respectively



Ion Source Labels

Serial Number Identification label on Ion Source

S/N: AOA000055

Warning label placed on the outside of the Source

Turn Off the Laser Before Opening the Ion Source

Turn Off the Power Before Connecting or Disconnecting the Fiber

High Voltage Warning labels placed on the outside of the Source



Control Unit Labels

Warning label for Control Unit Shutter

Turn Off the Power Before Connecting or Disconnecting the Optical Fiber

This is for placing inside the Control Unit on the Optics box

DO NOT OPEN
 No Serviceable Parts Inside

This is for placing inside the Control Unit on top of the LSI laser

LSI Laser 337-Si Inside
 Serial No.: S070247
 MFG: July, 2002

Identification and Certification label on Control Unit

Agilent **G1972A**

SERIAL NO: US23000062

Made in U.S.A . of domestic & foreign components

Electrical Information on the Control Unit

110-240 V ~
50/60 HZ, 1.9A
FUSE: F, 3.0A 250V
REPLACE WITH SAME TYPE AND RATING

Danger Labels placed on the Control Unit

DANGER
 INVISIBLE LASER RADIATION WHEN OPEN AND INTERLOCK DEFEATED. AVOID DIRECT EXPOSURE TO BEAM. REFER SERVICING TO QUALIFIED PERSONNEL.

DANGER
 INVISIBLE LASER RADIATION WHEN FIBER REMOVED AVOID DIRECT EXPOSURE TO BEAM